

Draft guidance on cement clinker production facilities

Table of contents

1	Introduction	2
2	Processes used, including consideration of input materials and behaviour of mercury in the process	3
2.1	Overview of the cement production process	3
2.2	The clinker production process	4
2.2.1	Description of clinker burning	4
2.2.2	Description of preheater rotary kilns.....	5
2.3	Input and behaviour of mercury in the process.....	5
2.3.1	Mercury content in different input streams.....	5
2.3.2	Mercury behaviour and mercury balances	6
3	Emissions Control Measures/Techniques	7
3.1	Primary measures.....	8
3.1.1	Input control (careful selection of input materials).....	8
3.2	Secondary measures.....	10
3.2.1	Dust shuttling	10
3.2.2	Dust shuttling with sorbent injection	12
3.2.3	Sorbent injection with polishing baghouse	14
3.3	Multi-pollutant control measures.....	16
3.3.1	Wet Scrubber	16
3.3.2	Selective catalytic reduction (SCR)	18
3.3.3	Activated carbon filter	19
4	Emerging Techniques.....	20
4.1	Mercury roaster.....	20
4.2	Sorbent Polymer Catalyst (SPC) Technology.....	21
5	Best available techniques and best environmental practices.....	21
5.1	Primary measures.....	21
5.2	Secondary measures.....	22
5.3	Multi-pollutant control measures	22
6	Monitoring.....	23

6.1	Introduction.....	23
6.2	Sampling points for mercury in the cement process	23
6.3	Chemical forms of mercury in the cement process	23
6.4	Mercury sampling and measuring methods for cement process	24
6.4.1	Material balance (Indirect Method)	24
6.4.2	Manual methods for mercury spot measurements (Impinger Methods)	25
6.4.3	Semi-continuous methods	25
6.4.4	Continuous emission monitoring systems for mercury (mercury CEMS).....	26
7	Appendix	27
7.1	Behaviour of mercury in clinker production plants	27
7.2	Emitted mercury species	33
8	References	34

1 Introduction

The production of cement requires considerable material input to burn clinker which is mixed with certain additives to form the final product: cement (Figure 1). Cement has become an indispensable material to construct buildings and infrastructure elements (bridges, tunnels, dams, sewers, power plants etc.). For the moment, there is no substitute in sight. For decades, the process to produce clinker has been subject to optimisation efforts. From an environmental point of view, this mainly concerns the reduction of energy consumption and the minimisation of emissions, especially to air. From the economic point of view, the focus is on the substitution of conventional fuels by alternatives, especially the use of waste-derived fuels with sufficient calorific value, also called alternative fuels. To a minor extent, conventional raw materials are also substituted by different types of waste, also called alternative raw materials. In some cases, alternative fuels and alternative raw materials are processed as part of the waste management infrastructure or owing to their availability.

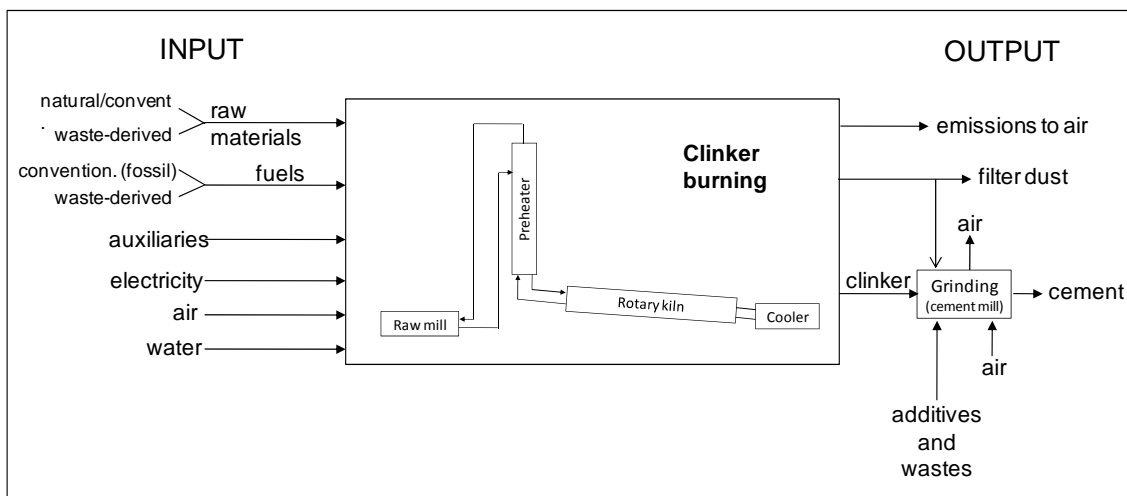

**Figure 1: Scheme on the principal input and output of cement plants
(Shoenberger, not published)**

The use of alternative fuels and/or alternative raw materials will not necessarily increase (or decrease) mercury emissions. It simply depends on the relative mercury contents of such materials. The use of waste-derived raw materials and fuels for the clinker burning process is called co-processing whereas the use of waste-derived fuels is sometimes known as co-incineration.

2 Processes used, including consideration of input materials and behaviour of mercury in the process

2.1 Overview of the cement production process

The production of clinker and cement, respectively, have the following sub-processes in common:

- raw materials (natural and waste-derived) – quarrying, storage, quality requirements, control and preparation
- fuels (conventional and waste-derived) – storage, quality requirements, control and preparation
- the kiln systems, kiln firing processes and emissions reduction techniques
- cement grinding – storage, quality requirements, control and preparation
- packaging and dispatch.

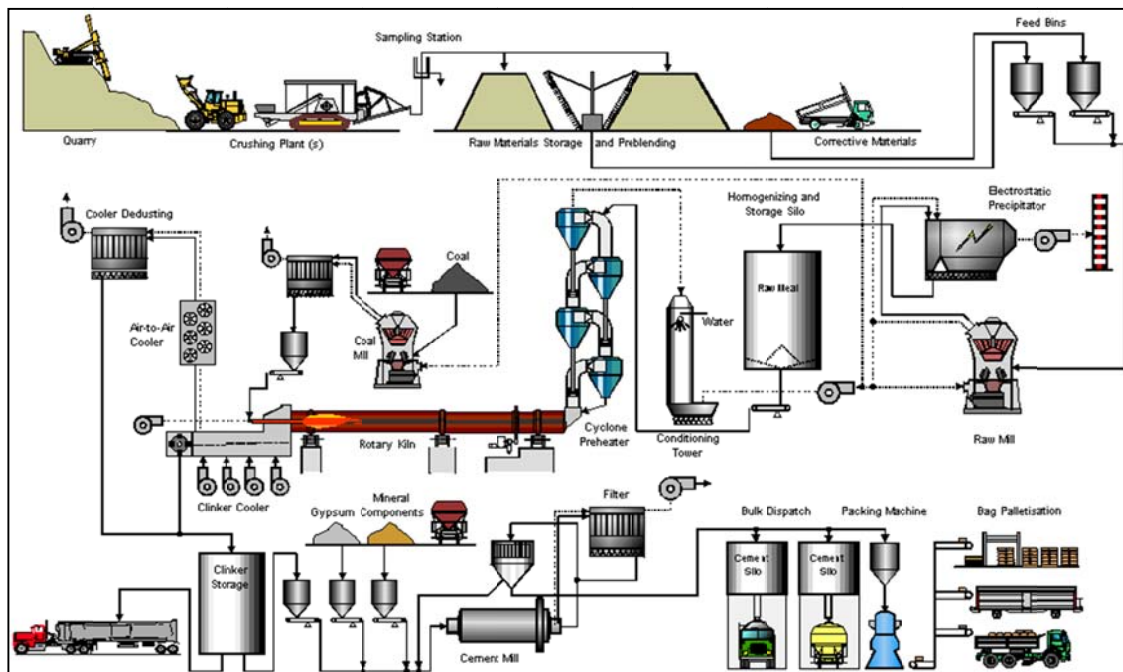

Figure 2: Overview of a cement works (BREF CLM, 2013)

In this document, the focus is directed on the clinker production process as it is the dominant source of mercury emissions to air.

2.2 The clinker production process

The basic chemistry of the clinker production process begins with the decomposition of calcium carbonate (CaCO_3) present in the raw material at about 900 °C to leave calcium oxide (CaO, lime) and liberate gaseous carbon dioxide (CO_2); this process is known as calcination. This is followed by the clinkerisation process in which the calcium oxide reacts at high temperature (typically 1,400 °C – 1,500 °C) with silica, alumina and ferrous oxide to form the silicates, aluminates and ferrites of calcium that comprise the Portland clinker (SC BAT Cement, 2008).

Basically, the clinker production process consists of the clinker burning as such (preheating, kiln firing process with or without precalcination, and with or without a kiln-gas bypass) followed by the clinker cooling. The burnt clinker is fed to the cement mill where clinker is ground together with additives to produce the final product (i.e., cement).

2.2.1 Description of clinker burning

There are four main process routes for the manufacture of cement – the wet, semi-wet, semi-dry and dry processes. The choice of process is, to a large extent, determined by the state of the raw materials (dry or wet).

- i. In the wet process, the raw materials are ground with water to form a pumpable slurry with a water content of 28 – 42 per cent. The slurry is directly fed into the kiln. The production capacity of this process is between 100 and 3,600 metric tons/day (t/d). The wet process requires more energy, and is thus more expensive to operate.
- ii. In the semi-wet process, the slurry is first dewatered in filter presses. The residual water content varies between 18 and 23 per cent. The filter cake is extruded into pellets and fed to a grate preheater. This type of kiln with grate preheaters were developed by O. Lellep and the company Polysius; thus, these kilns are called Lepol kilns (Locher, 2000, p 58). The production capacity of this process is between 100 and 3,000 t/d.
- iii. In the semi-dry process, dry raw meal is pelletised with water and fed into a grate preheater before the kiln. This type of kiln is also called Lepol kiln. However, the water content of the feed is further reduced to 11 – 14 per cent. The production capacity of this process is between 500 and 3,200 t/d. Plants using semi-dry processes are likely to change to dry techniques whenever an expansion or a major improvement is required.
- iv. In the dry process, the raw materials are ground and dried to raw meal in the form of a flowable powder with a water content of less than 1 per cent. The dry raw meal is fed to a cyclone preheater (4 to 6 stages) or a precalciner kiln, or more rarely, to a long dry kiln. Kilns with preheaters are more energy efficient and are significantly shorter (40 – 100 m). Dry process kilns are the vast majority of existing kilns. Production capacity may vary between 500 and >10,000 t/d.

2.2.2 Description of preheater rotary kilns

Rotary kilns are refractory-lined steel tubes with a diameter of up to about 6 meters and a length to diameter ratio of between 10:1 and 38:1. They are inclined at a slope of 2.5-4 per cent and rotate at 0.5-5.0, usually 1.2-3, revolutions per minute. As a result of the inclination and rotation of the tube, the material to be burned, fed into the inlet of the kiln moves down the tube. Thus, it moves towards the flame burning at the outlet (Locher, 2000, p 55; Ullmann's, 1986; BREF CLM 2013). Thus, the gas stream is flowing counter-currently to the solids. All long wet and long dry kilns are equipped with internals (chains, crosses) to improve heat transfer. Vertical shaft kilns are not described here as they show low energy efficiency and poor environmental performance.

The precalciner technology, as illustrated in Figure 3, was developed in the 1960s in order to increase production capacity for a given kiln size. Prior to 1993, in Europe, many of the 4-stage cyclone preheater kilns, most of the 5-stage cyclone preheater kilns, and all of the very few 6-stage cyclone preheater kilns were equipped with a precalciner and a tertiary air duct (Erhard/Scheuer, 1993). Since then, precalciners are being retrofitted. New plants are always equipped with precalciner technology. The precalciners are positioned between kiln and preheater and hot air from the clinker cooler is provided via the tertiary air duct (Figure 3). They provide flexibility to use different kinds of alternative (waste-derived) fuels, which may have lower calorific value.

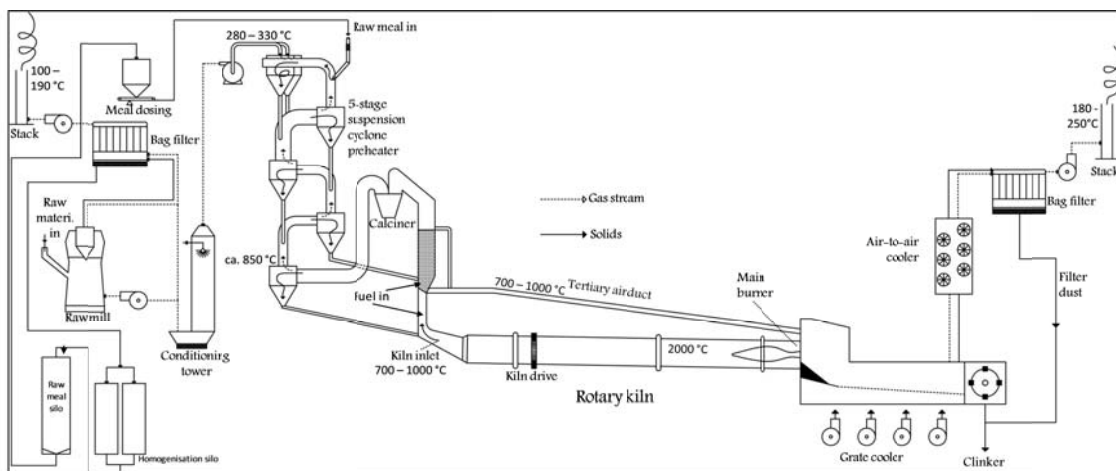

Figure 3: Dry kiln system with a precalciner (Shoenberger, not published)

2.3 Input and behaviour of mercury in the process

2.3.1 Mercury content in different input streams

Mercury can be present in all types of input mass streams, i.e. in the natural and waste-derived raw materials as well as in the conventional and waste-derived fuels. This means, that mercury enters the clinker production systems by all three principal feeding points, i.e. via the raw materials, the main burner and the secondary firing system.

Based on available sources, the mercury content of the input mass streams is compiled in Table 1. This compilation confirms that all inputs can contain mercury. However, it should be noted that mercury contents can be significantly higher than presented in Table 1.

	FZKA, 2003			Renzori et al., 2010		Bref CLM, 2013		Oerter, 2007	CH Buwal, 1999			US PCA, 2006
	Min	Max	Av	Min	Max	Min	Max	50 percentile	Min	Max	Av	Av
Natural or conventional raw materials												
Limestone	0.005	0.1	0.04	< 0,005	0.4	< 0,01	0.13	0.02				0.017
Marl	0.005	0.1	0.03									0.052
Clay	0.01	0.5	0.2	0.002	0.45	0.02	0.15	0.09				
Sand	0.01	1	0.02	< 0,005	0.55			0.03				0.029
Gypsum				< 0,005	0.08							
Iron ore		1	0.5	0.001	0.8			0.17				0.078
Raw meal	0.008	1	0.06	0.01	1	0.01	0.5	0.03	0.02	0.6	0.07	
Alternative raw materials												
Spent foundry sand	0.03	4.4	0.3					0.02				
Synthetic Gypsum anhydrite	0.06	1.3	0.1	0.03	1.3							
Blast furnace slag	0.01	1	0.6	< 0,005	0.2							0.012
Ash from burning processes, ~ bottom ash from lignite	0.003	1.4	0.3									
Coal fly ash	0.04	2.4	0.3	< 0,002	0.8			0.34				0.2
Conventional fuels												
Hard coal	0.01	3	0.3	0.1	13	0.1	3.3	0.4	0.1	3.3	0.42	
Lignite	0.01	0.7	0.2	0.03	0.11			0.09				
Heavy oil				0.006								0.006
Pet coke	0.01	0.09	0.05	0.01	0.71			< 0,5				
Alternatives fuels												
Waste tyres	0.1	1	0.4	0.01	0.4			0.17				
Waste oil	0.01	2	0.3					0.1	0.001	0.2		
Waste wood	0.01	1	0.2					0.18	1	0.31	0.37	
Fractions from municipal, commercial and industrial waste	< 0,01	1.4	0.3									
Fractions of industrial waste								0.25				
Fractions of municipal waste								0.26				
Meat and bone meal			0.2									
Municipal sludge	0.3	2.5		0.31	1.45				1	5	2.6	
Liquid waste-derived fuel				< 0,06	0.22							
Solid waste derived fuel				< 0,07	2.77							
Oil shale (also a raw material)	0.05	0.3	0.2	0.05	0.3							0.057

Table 1: Average values and ranges of the mercury content of natural and alternative raw materials as well as of conventional and alternative fuels according to different sources, values in [ppm]

Legend: Min: minimum; Max: maximum; Av: average

2.3.2 Mercury behaviour and mercury balances

Due to the high volatility of elemental mercury and most of mercury compounds, the mercury content in the clinker is nil or negligible (Weisweiler/Keller, 1992; Kirchartz, 1994, pp 57 and 63; Locher, 2000, p 156; Eriksen et al., 2007; Renzoni et al., 2010, pp 57, X and XIII). As the raw materials and fuels are burned, mercury is released and an external mercury cycle is formed.

As a consequence of the external cycle, mercury concentrates between the preheater and the dust abatement facilities (electrostatic precipitator or bag filter), often just called dust filter. However, a part of the mercury is always emitted with the kiln waste gas. If no filter dust is discarded, practically all mercury input will be finally emitted with the waste gas (Weisweiler/Keller, 1992; Paone, 2008; Linero, 2011; egra, 2013). This is logical as mercury does not end up in the clinker, the only way mercury can leave the system is its emission with the waste gas. In order to quantify the enrichment of mercury in the external cycle as well as the percentage of its emission with the waste gas, mercury balances need to be carried out.

It has to be stressed that achieving a mercury balance requires considerable time as it should be carried out at steady-state conditions which could take nearly a month to achieve (Paone, 2008). Therefore, a balance should be carried out for at least a week, whereby a high frequency of sampling (e.g. hourly averages) is required in order to see the variations. In practice, such a long investigation period is often not maintained.

A mercury balance was published in the form of Sankey diagrams in 2002 (Schäfer/Hoenig, 2002), which has been referenced numerous times (Oerter, 2007; Renzoni et al., 2010; Oerter/Zunzer, 2011; Zheng et al., 2012; Hoenig, 2013; ecra, 2013). The diagrams are given in Figure 4 below. It is the result of a so-called outer mass balance where the raw materials and fuels are the input and the clinker, removed dusts (in case of a chlorine bypass and/or when filter dust is removed) as well as emissions to air of the kiln, raw mill, cooler and chlorine bypass (Sprung, 1988) are the output. The chart on the left shows the mercury balance without and the chart on the right with filter dust removal.

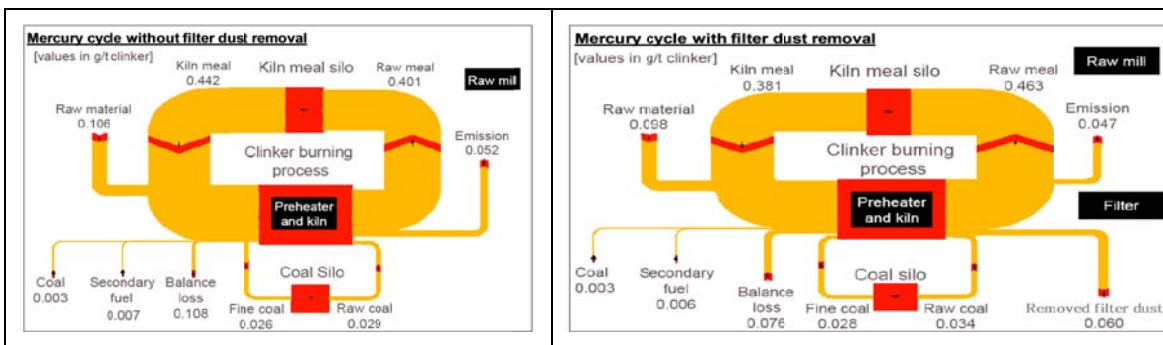

Figure 4: Sankey diagrams of the mercury balance of a clinker production plant without and with filter dust removal, based on (Schaefer/Hoenig, 2002)

The mercury balance has been carried out by continuous mercury monitoring at the stack and by taking hundreds of solid samples (Schäfer/Hoenig, 2001). The left chart of Figure 4 indicates that during the balancing period, only half of the mercury input was emitted. However, without control, eventually all mercury will be emitted via the stack.

The chart on the right shows that the mercury cycle is reduced by removing filter dust from the system.

Figure 4 also indicates that the kiln feed silo is a considerable reservoir for mercury.

In both cases the balance loss represents the mercury stored in the kiln meal silo during the balancing period and the uncertainties of the determination of all (input and output) mass flows and mercury concentrations.

More details on the behavior of mercury in clinker production plants are included in the Appendix (section 7).

3 Emissions Control Measures/Techniques

This section describes control measures/techniques applicable to new and existing sources to reduce mercury air emissions from the cement clinker production process. The emissions control

measures/techniques are additional to, or are used in conjunction, with the emissions control measures/techniques described in the introductory section of the BAT/BEP guidance document as common emission controls across source categories.

The specific level of mercury control/reduction for a cement clinker production process applying one or more of the measures/techniques described in this chapter can be determined using the emissions monitoring techniques described in section 6 of this chapter and the introductory section of the BAT/BEP guidance document.

3.1 Primary measures

3.1.1 Input control (careful selection of input materials)

Mercury enters the kiln system as a trace element naturally present in raw materials and, to a lesser extent, in fuels. A careful selection and control of all substances entering the kiln in order to reduce mercury input along with the use of effective air pollution control devices is very important for reducing mercury emissions from cement clinker production.

Many kilns may be able to reduce emissions by substituting certain components like clay or sand by lower-mercury raw materials than they now use. Substitution for the principal raw material, limestone, is more unlikely than for the other additives. Limestone constitutes 75 to 100 per cent of the raw material used to make clinker and most plants are located at their source of limestone for economic reasons. Purchasing limestone from other locations would usually be too costly due to transport costs. In addition, limestone quarries are often owned by the cement plant or its parent company and would not be available to other cement plants with different ownership. The characteristics of the limestone, including the mercury content, is especially relevant when choosing location for a new facility.

Mercury concentrations in raw materials (limestone, marl or clay) vary significantly from quarry to quarry. There are even cases where mercury concentrations vary significantly within a single deposit, thereby sometimes requiring selective mining. In those cases, after exploration and analyses of the quarry, it is in principle possible to define specific parts of the quarry with higher mercury concentrations and to use limestone from zones where the concentration is lower. In many cases such a procedure is complex to manage and cannot always be carried out.

Other non-limestone raw materials (e.g., clay, shale, sand, and iron ore), however, are typically purchased from various offsite sources and transported to the plant. Plants may have access to lower-mercury materials, although the extent to which this is feasible would have to be determined on a site-specific basis. “Corrective” materials such as bauxite, iron ore or sand may be required to adapt the chemical composition of the raw mix to the requirements of the process and product specifications.

To a limited extent, alternative raw materials are used to substitute natural raw materials and correctives.

In cases where alternative raw materials lead to a significant increase in the mercury intake into the system they may have to be replaced by another alternative material. Fly ash, for example, can have a higher or lower mercury content than the raw materials it replaces so the source of fly ash may have to be carefully selected.

The cement production process usually uses conventional fuels such as coal, gas, petroleum coke and oil as well as alternative fuels (tires, waste derived fuels, etc.). Selecting fuels, including alternative

fuels, with a low mercury content as well as the technique to measure mercury in the fuel and a quality assurance system to guarantee the characteristics of the fuels used are therefore very important for reducing mercury emissions from cement clinker production.

Commonly the cement plant permits specify which waste derived raw materials and fuels the plant is allowed to use or burn. The mercury content in alternative raw materials and fuels can also be limited in the permit as well as requirements to analyse periodically and when they make a raw material or fuel switch to make sure that they keep within the limit. The permit of Cementa AB, Slite, in Sweden has a limit of less than 2 ppm mercury in some specified waste derived fuels.

Examples of limit values for mercury content in wastes used in cement plants in some countries are given in Table 2.

Type of waste	Austria	Germany	Switzerland
Plastic	2	1.2	
Paper	2	1.2	
Spent oil, solvents	2	1	
Sewage sludge	3		
Combustible waste in general	0.5		0.5
Waste used as raw material			0.5

Table 2: Examples of limit values for mercury content in some wastes used in cement plants, values in mg/kg dry substance [ppm] (BREF CLM, 2013)

Achieved environmental benefits

Reduced mercury emissions and/or consistent levels of mercury emissions at as low level as possible. In 2014, 60 per cent of the fuels used at Cementa AB, Slite, in Sweden were alternative fuels. Due to low content in the limestone and effective input control, mercury emissions were 0.0014 mg Hg/Nm³ (average over the sampling period, periodical measurements at reference conditions 273 K, 101,3 kPa, 10 per cent oxygen and dry gas). The plant also has a wet scrubber for SO₂ abatement but the effect of it on mercury emissions has not been analysed.

Applicability

Input control can be applied at all cement plants.

Reference plant

Cementa AB: Slite, Sweden

3.2 Secondary measures

3.2.1 Dust shuttling

A proven technology to limit the build-up of mercury levels within the kiln dust is the selective shuttling or “bleeding” of mercury enriched kiln dust.

The mercury enriched kiln dust is extracted from the dust and mercury circulating in the kiln (see section 4.2). Following its extraction, the dust is reintroduced directly at the finish mill (after the kiln) with clinker and gypsum.

Dust shuttling can be done in 2 configurations:

1. “Raw mill off” (kiln is operating alone): dust shuttling is efficient to remove mercury. The collected dust is dust from the preheater which has - relatively - higher mercury concentrations because it is not “diluted” inside the raw mill.
2. “Raw mill on” (kiln and raw mill are operating in line because kiln gases are drying the raw meal inside the raw mill): dust shuttling is less efficient to remove mercury. The collected mercury enriched pre-heater dust is “diluted” inside the raw mill. It should be noted that this case is subdivided in 3 configurations:
 - Plants equipped with vertical raw mill => all kiln gases go through raw mill => very little mercury in filter dust => better to do “raw mill off” dust shuttling only; this also applies to plants with ball mill and high raw material moisture content;
 - Plants equipped with ball raw mill => some kiln gases may bypass the raw mill => could consider to do some “raw mill on” dust shuttling on the “bypass steam” if this stream is equipped with a separate dust filter;
 - Plants equipped with a “bleed” filter separate from the main “kiln and raw mill” filter. This smaller “bleed” filter is fed with pre-heater gas. Dust shuttling from this filter is efficient as long as all the remaining gas goes through the raw mill.

The temperature in the dust collector is significant. The vapour pressure of mercury drops significantly with reduced temperature (see Figure 7.5 of the appendix). Furthermore Figure 5 shows that the adsorption of mercury on the dust surface increases as the temperature falls. This effect mainly applies to oxidized mercury and much less to elemental mercury. For a good efficiency of dust shuttling technology the gas temperature must be below 140 °C and preferably at/below 120 °C. In “raw mill on-“operation the gas temperature in the filter is usually between 90 and 120 °C. In “raw mill off-“operation it is usually 140 – 170 °C and can be up to 200 °C. That means that for an efficient dust shuttling the temperature in “raw mill off-“operation must be reduced in a conditioning tower or by quenching with air to a temperature range of 120 – 140 °C. Reducing the temperature below 140 °C by water conditioning often results in corrosion of the system due to sulfuric acid condensation unless the walls of the dust collector and ducting are extremely well insulated. Often the hoppers of the dust collector must be heated. Therefore, appropriate technical measures have to be taken in order to avoid corrosion.

The precipitated dust can be removed from the system independently from the filter type. In some cases where ESPs are used, it has been proven to be more effective to remove only the dust from the last section (which is usually the finer part of the dust with a higher specific surface). In other cases

this has not been observed. The dust should be collected in a separate silo in order to be able to be flexible regarding the further usage. In many cement plants the dust is used as a mineral addition to the cement, which is in line with most cement standards. If this is not possible the dust can be used for the production of other products, like certain binders or, if that is not possible, it has to be treated as waste.

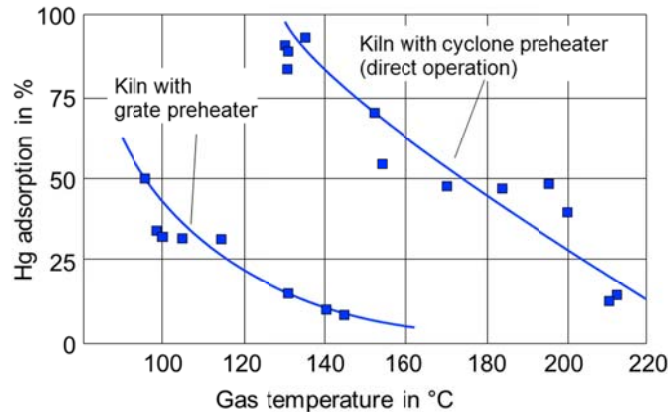

Figure 5: Comparison of mercury adsorption in grate and cyclone preheaters depending on clean gas temperature (Kirchartz, 1994)

The efficiency of the technique can be enhanced by adding sorbents with a high surface of specific chemical properties (e.g. activated carbon or calcium based sorbents) to increase the rate of mercury bound to particles (see section 3.2.2).

Achieved environmental benefits

The major environmental benefit is the reduction of mercury emissions. The reduction potential can be significant mainly depending on the waste gas temperature, the percentage of dust shuttled (removed) and the ratio of direct and compound operating mode (see also Figure 7.9 in the appendix). The removal efficiency needs to be determined over a longer time period of at least several days or weeks. Experience shows that with this technique, mercury emissions can be reduced by 10 – 35 per cent. Experiences from German cement plants show that using this technique also reduces air emissions of some other compounds like ammonia.

Cross-media effects

When the shuttled dust is used as an addition to cement, the mercury will be shifted to the final product. If the dust is distributed evenly in the final product, then the mercury concentration will be similar to that in the original raw materials. The mercury content of the final product should be monitored. Once the cement will be hydrated, the mercury will be bound to the matrix. If the shuttled dust can't be used in the final product then it will have to be disposed appropriately.

Applicability

The dust shuttling technique can in principle be applied in all cement plants. It is most effective in preheater/precalciner kilns during “mill off-“operation or in a “mill off-“string, in case only a part of the exhaust gas is used in the raw mill. In other configurations (e. g. at long dry kilns), the technology is less efficient because the exhaust gas is commonly above 200°C. The achievable efficiency depends on a number of parameters including:

- relation of oxidized and elemental mercury in the exhaust gas
- the relation of “raw mill on-“ / “raw mill off-“ operation
- the relation of raw mill and kiln capacities
- the achievable exhaust gas temperature in “raw mill off-“ operation
- the availability of a separate silo for the removed dust
- the possibilities of using the dust
- the level of mercury enrichment in the system (a lower enrichment means that more dust or meal has to be removed from the system)

Reference plants

- Cemex: Brooksville, Florida/USA

3.2.2 Dust shuttling with sorbent injection

Dust shuttling combined with sorbent injection achieves higher mercury removal efficiency than using dust shuttling alone. The sorbents are usually injected during raw mill off-operation aiming at cutting peak emission in this operation mode, which also reduces the amount of sorbent necessary to control mercury emissions to desired levels. Apart from very few cases (with specific input conditions) the injection of sorbents is not required in raw mill on-operation, because the mercury capture in the raw mill is sufficient to control mercury emissions to desired levels.

Several sorbent types are available on the market, e.g. carbon, activated carbon, activated lignite (lignite coke), zeolites and reactive mineral mixtures containing active clay or calcium compounds.

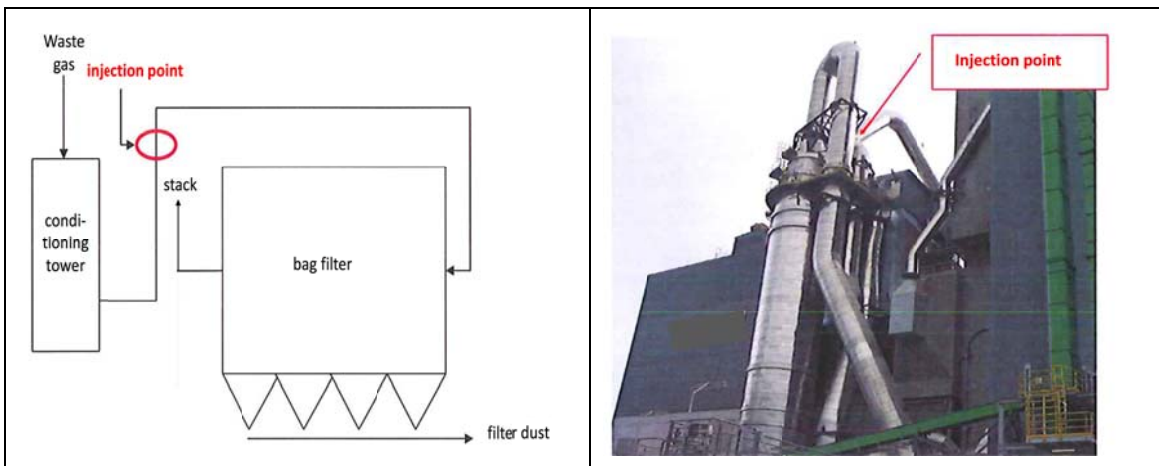

Figure 6: Illustration of injection of activated lignite (lignite coke) into the flue gas between conditioning tower and bag filter

The flue gas temperature should be as low as possible, preferably below 130 °C, in order to have high adsorption efficiency. The injection can be carried out via a big bag containing the sorbent and a dosing unit.

After starting the dosage of sorbent, the reduction of mercury emissions can be recognised within a couple of minutes (Figure 7).

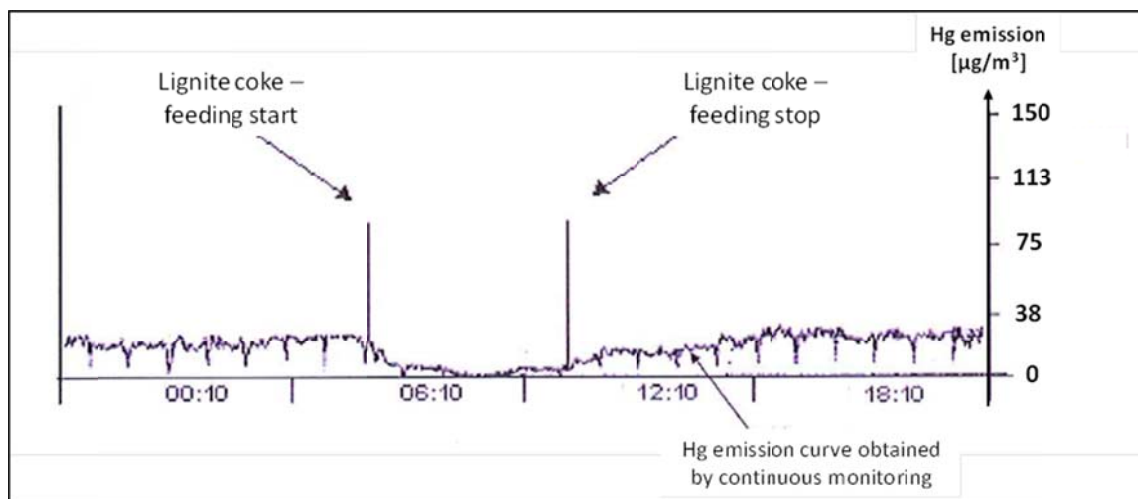

Figure 7: Example of reduction of mercury emissions by injection of lignite coke; the emission curve shown is gained from continuous mercury monitoring of the waste gas in the stack

The use of sorbents requires removal of the dust contaminated with the mercury laden sorbent. This is why sorbent injection can be seen as a measure to improve the capture efficiency of dust shuttling. As the dust shuttling technique works better with oxidized mercury than with elemental mercury, the adsorption capacity may be further increased by additives such as bromine, sulfur or more complex compounds with similar chemical properties. In a few cement plants sorbents impregnated with bromines or sulfur have been used in order to improve the mercury capture efficiency.

When aiming at cutting peak emissions, the dosage period may last only a few hours per day. Then, it is most likely that the dust with mercury laden sorbent can be added to the cement mill. In case of continuous injection, dust with mercury laden sorbent may have to be disposed of separately as the addition of large amounts of dust with mercury laden sorbent to the cement can have an adverse impact on the cement quality. If the removed dust is used as cement constituent in the cement mill, possible impacts on cement quality have to be monitored.

Achieved environmental benefits

Dust shuttling with sorbent injection can achieve very low mercury emission levels. Mercury emissions can be reduced by 70 – 90 per cent. The emission level depends on which target concentration the system is designed to achieve. In Germany some cement plants have installed sorbent injection systems designed to keep mercury emission levels below of 0.03 mg/Nm^3 as daily mean value and 0.05 mg/Nm^3 as half-hourly mean value at reference conditions 273 K, 101,3 kPa, 10 per cent oxygen and dry gas. For the example provided (Figures 6-7), the achieved mercury concentration is below 28 µg/Nm^3 (daily mean value at reference conditions 273 K, 101,3 kPa, 10 per cent oxygen and dry gas).

Cross-media effects

When the shuttled dust is used as an addition to cement, the sorbent and the mercury will be shifted to the final product. If the dust is distributed evenly in the final product, then the mercury concentration will be similar to that in the original raw materials. In this case the mercury content of the final product should be monitored. However, there should not be any mercury air emissions from these products. Furthermore the impact of the sorbent on cement quality shall be monitored and controlled.

If the shuttled dust cannot be used in the final product then it will have to be disposed of appropriately.

Applicability

This technique is applicable to new and existing installations. The use of sorbents for mercury air emission reduction has been reported mainly in the U.S. and Germany.

Dust shuttling with sorbent injection is more expensive than dust shuttling alone. However, because the effectiveness of dust shuttling is very dependent on site specific factors, sorbent injection is more widely applicable and can achieve lower overall mercury emission levels.

Cost

When aiming at cutting peak emissions, where the sorbent is dosed only a few hours a day, the operating costs are low. Only costs for electricity (fan and dosing unit) and consumption of sorbent (about one big bag per day which corresponds to about one metric ton) have to be covered. The specific costs are in the range of 0.06 – 0.08 US\$/metric ton clinker. At these levels, it is most likely that the sorbent contained in the filter dust can be added to the cement. Consequently, no additional disposal costs have to be covered.

In case of continuous injection, if the dust with mercury laden sorbent cannot be added to the cement mill it has to be disposed of properly.

The investment costs for the bag filter and dosing unit are about 50,000 – 100,000 US\$ depending on the supplier and plant capacity.

Reference plants

- Lafarge Zement Wössingen Ltd. ,Walzbachtal/Germany (recently sold to CRH Irish Cement)
- Cemex OstZement GmbH, Rüdersdorf/Germany
- Holcim Zementwerk Beckum, Kollenbach/Germany (before Cemex)
- Lehigh Cement: Cupertino, California/USA
- Lehigh Cement: Tehachapi, California/USA

3.2.3 Sorbent injection with polishing baghouse

In this technique sorbent is injected downstream of the main particulate control combined with a polishing filter to remove the mercury laden sorbent. Depending on the mercury emissions removal requirement the sorbent can be injected continuously, or for cutting peak emissions which typically occur during raw mill off operation.

In order to avoid mixing the mercury laden sorbent with the preheater dust, the sorbent (e.g., activated carbon) is injected into the flue gas after the main dust control and a second dust filter or “polishing” baghouse is used to capture the spent carbon. A second dust filter is not common in the cement industry because of the additional capital investment. Figure 8 below illustrates the use of sorbent injection with a polishing baghouse.

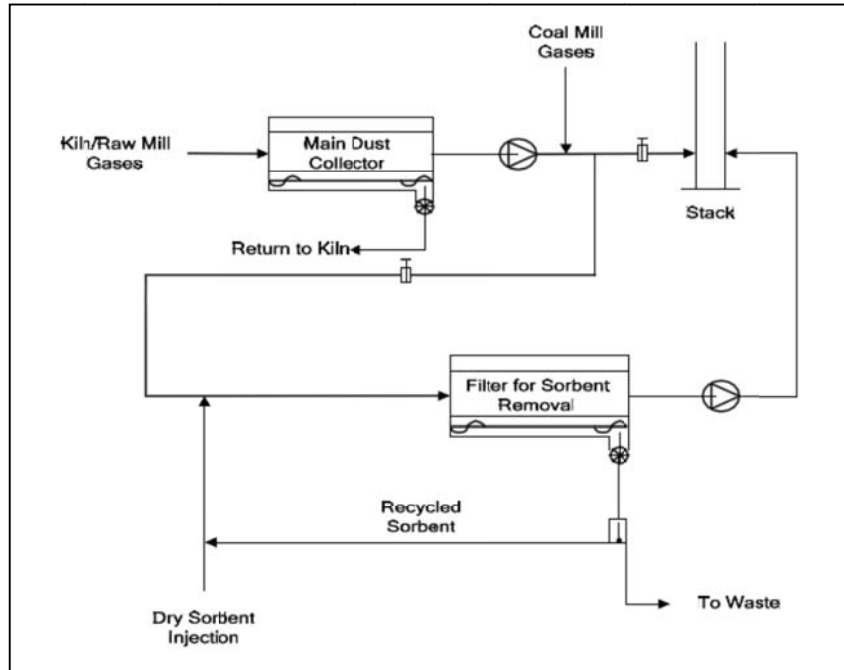

Figure 8: Example for the injection of activated carbon downstream to the dust filter requiring an additional filter for sorbent removal (Paone, 2009, p 55)

There are a number of variables that affect the adsorption of mercury on sorbents, and therefore, the efficiency of mercury control. These variables include:

- mercury speciation and concentration
- sorbent physical and chemical properties such as particle size distribution, pore structure and distribution, and surface characteristics
- flue gas temperature
- flue gas composition
- sorbent concentration (i.e., injection rate)
- mercury-sorbent contact time
- adequacy of sorbent dispersion into the mercury containing gas stream (Zheng, 2011).

Furthermore, filter bag type and filter air-to-cloth ratio also affect the amount of mercury that can be adsorbed.

Results from a study to assess key design parameters for a full-scale mercury emission control installation at a cement plant in the U.S. determined that in order to achieve higher mercury control, untreated activated carbon performs comparably to halogen-treated activated carbon (avoiding other potential issues associated with use of halogens, for example corrosion) (US Cement 2007). In addition, the waste gas temperature should be low in order to achieve high adsorption rates (Renzoni et al, 2010).

Achieved environmental benefits

The use of activated carbon injection with a “polishing” baghouse can achieve 90 per cent mercury removal. (Barnett, 2013)

Cross-media effects

The mercury laden dust from this process will have to be disposed of properly.

Applicability

This technique can be applied at all cement kilns. Depending on the required overall mercury emissions removal requirement the sorbent can be injected continuously, or for cutting peak emissions, which typically occur during raw mill off operation.

In the U.S. a cement plant has successfully installed and operated an activated carbon injection system, where the activated carbon is injected into the flue gas after the main dust control followed by a “polishing” baghouse, to control mercury emissions. The kiln system at the plant is a preheater/precalciner system, which includes the rotary kiln, a preheater/precalciner tower, and the associated air pollution control system. The plant is equipped with an in-line raw mill, where the gases from the kiln system are routed directly to the raw mill to provide the heat to dry the raw materials. During operating times when the raw mill is off (approximately 15 per cent of the annual operating time frame), the gases bypass the raw mill and are routed directly to the baghouse. The plant typically, consumes 1,500,000 short tons per year of raw materials and has the capacity to produce 1,000,000 short tons of clinker annually (US Cement 2007).

Economics

The U.S. EPA cost analysis for installing activated carbon injection (ACI) to control mercury at a cement kiln includes a polishing baghouse. These costs were estimated using costs that were originally developed for electric utility boilers. Using exhaust gas flow rates as the common factor, control costs for electric utilities were scaled to derive control costs for Portland cement kilns. Capital and annual cost factors (\$/ton of clinker) were developed using the boiler costs and gas flow data for the different size boilers. In the U.S., the total capital costs to install sorbent injection with a polishing baghouse at a new 1.2 million short ton per year kiln were calculated at \$3.2 million (2005 USD). Annualized costs were calculated at \$1.1 million per year. (US Cement, 2010 Cost)

Reference plants

- Ash Grove Cement: Durkee, Oregon (USA)

3.3 Multi-pollutant control measures

Air pollution control devices installed for removing nitrogen oxides and sulfur oxides can also achieve co-benefits of mercury capture, and are especially effective on Hg²⁺ emissions.

3.3.1 Wet Scrubber

The wet scrubber is a proven technique for flue gas desulfurization in clinker production processes where SO₂ emissions control is necessary.

In a wet scrubber the SO_x is absorbed by a liquid or slurry which is sprayed in a spray tower. The absorbent is calcium carbonate. Wet scrubbing systems provide the highest removal efficiencies for soluble acid gases of all flue-gas desulfurisation (FGD) methods with the lowest excess stoichiometric factors and the lowest solid waste production rate. However, wet scrubbers also significantly reduce the HCl, residual dust, NH₃ and, to a lesser extent, metals, including mercury emissions.

The slurry is sprayed counter-currently to the exhaust gas and collected in a recycle tank at the bottom of the scrubber where the formed sulfite is oxidised with air to sulfate and forms calcium sulfate dihydrate. The dihydrate is separated and depending upon the physico-chemical properties of gypsum this material can be used in cement milling and the water is returned to the scrubber.

Gaseous compounds of oxidized mercury are water-soluble and can absorb in the aqueous slurry of a wet scrubber system, and therefore, a fraction of gas-phase oxidized mercury vapors may be efficiently removed. However, gaseous elemental mercury is insoluble in water and, therefore, does not absorb in such slurries. The speciation between oxidized mercury and elemental mercury can vary significantly between kilns and is also dependent on the process conditions of the kiln operation, all of which will affect the amount of mercury that is removed in a wet scrubber. In wet desulfurisation processes gypsum is produced as a by-product which is used as a natural gypsum replacement added to the clinker in the finish mill.

Achieved environmental benefit

In the U.S. five cement kilns have limestone wet scrubbers installed to control SO₂ emissions which also co-control mercury air emissions. Based on stack tests and data from those five limestone wet scrubbers, up to 80 per cent of the total mercury air emissions are co-controlled (i.e., removed). (Barnett, 2013)

Applicability

A wet scrubber is typically used in cement plants with high SO₂ emissions.

For cement plants this technique is most effective where the dominant emissions of mercury are in the oxide form. If there are significant levels of elemental mercury, wet scrubbers are not effective unless additives to oxidize the mercury are used.

Cross-media effects (other than mercury related)

- Increased energy consumption.
- Mercury shifted to by-product production such as gypsum.
- Increased waste production from flue-gas desulfurisation (FGD), and when maintenance is carried out, additional waste may occur.
- Increased CO₂ emissions.
- Increased water consumption.
- Potential emissions to water and increased risk of water contamination.
- Increased operational cost.
- Replacement of natural gypsum

Economics

In 2000, the investment costs for the scrubber of Castle Cement (including plant modifications) were reported to be €7 million and the operating costs were about €0.9 per metric ton clinker. In 1998 for Cementa AB in Sweden, the investment costs were about €10 million and the operating costs were about €0.5 per metric ton clinker. With an initial SO₂ concentration of up to 3 000 mg/Nm³ and a kiln capacity of 3,000 metric ton clinker/day, the investment costs in the late 1990s were €6 million –10 million and the operating costs €0.5 –1 per metric ton clinker. For a reference cement plant with a capacity of 1,100 metric tons per day a wet scrubber operated to 75 per cent SO_x reduction was

calculated to have investment costs of €5.5 million, variable operating costs of €0.6 per metric ton of clinker and total costs of €3 per metric ton of clinker (year 2000 data, 10 years lifetime, 4 per cent interest rate, include electricity, labour and lime costs). In 2008, the European cement industry reported investment costs of between €6 million and 30 million and operational costs of between €1–2 per tonne clinker. (BREF CLM 2013)

In the U.S, the total capital costs to install a wet scrubber at a new 1.2 million short ton per year kiln, including the cost of a continuous emissions monitoring system (CEMS), were calculated at \$25.1 million per kiln (2005 USD). Annualized costs, including monitoring, were calculated at \$3.6 million per year per kiln. (US Cement, 2010 Cost)

Reference plants

- Cementa AB: Slite, Sweden
- Holcim: Midlothian, Texas/USA
- Lehigh Cement: Mason City, Iowa/USA

3.3.2 Selective catalytic reduction (SCR)

SCR reduces NO_x emissions by injecting NH₃ or urea into the gas stream which reacts on the surface of a catalyst at a temperature of about 300–400 °C. The SCR technique is widely used for NO_x abatement in other industries (coal fired power stations, waste incinerators) and has been applied in the cement industry since the 1990s (CEMBUREAU, 1997; Netherlands, 1997) in 6 cement plants worldwide (Germany, Italy and U.S.) The SCR catalyst consists of a ceramic body which is doped with catalytically reactive compounds like V₂O₅ or the oxides of other metals. The main task of the SCR technique is to reduce catalytically NO and NO₂ in exhaust gases to nitrogen.

In the cement industry, basically two systems are considered: low dust configuration between a dedusting unit and stack, and a high dust configuration between a preheater and a dedusting unit. Low dust exhaust gas systems require the reheating of the exhaust gases after dedusting, which may cause additional energy costs and pressure losses. High dust systems do not require reheating, because the waste gas temperature at the outlet of the preheater system is usually in the right temperature range for SCR operation. On the other hand, Low Dust systems don't have problems with the high dust load before filter and thus allow much longer operation time of the catalyst. Furthermore, they are installed at lower temperature (smaller volume flow) allowing smaller number of catalyst layers.

From experience in the power sector it is well known that – as a side effect – on the surface of SCR catalysts elemental mercury is oxidized to a certain extent. This oxidized mercury can then better be removed from the gas stream in a subsequent dust filter or wet scrubber. This means that with the SCR technique elemental mercury will be transformed into species which are easier to capture.

Currently extensive research is carried out to improve the applicability of SCR technology for NO_x abatement in the cement industry. Investigations at European cement plants (Germany, Austria, Italy) indicate that the oxidizing effect on elemental mercury is observed if SCR technique is applied in the exhaust gas of cement plants. This effect can only be achieved if a capture system is located after the SCR catalyst. That means that it works in combination with High-Dust-SCR, but not with Tail-End-(Low Dust-) SCR.

Achieved environmental benefits

As an indirect environmental benefit elemental mercury is partly transformed into oxidized mercury. As a side effect it can improve Hg capture in combination with dust shuttling and wet scrubber.

Cross-media effects (other than mercury related)

The power demand of the cement plant increases by 5-6 kwh/t clinker, lowering the energy efficiency of the process and increasing indirect GHG emissions. Furthermore additional waste is produced containing rare metals.

Operational experience

Currently four SCR installations are in operation in Europe and a few more are in operation (or demonstration) around the world. Quantification of the mercury oxidizing effect requires further investigation.

Applicability

The mercury oxidizing side effect can be achieved only in cement plants which are equipped with the High-Dust-SCR technique. The increase in Hg reduction can be achieved in combination with dust shuttling or with a wet scrubber.

Economics

The results from the use of the SCR technique have shown a cost level of EUR 1.25 to 2.00 per tonne of clinker, depending on the plant size and the NO_x removal efficiency required. The economics of the SCR technique is dominated by the investment costs. The use of catalysts increases the operational costs due to higher energy consumption due to pressure drop and cleaning air for the catalyst. Specific operating costs of SCR have declined to around EUR 1.75 – 2.0 per tonne of clinker. (BREF CLM, 2013)

Reference plants

- High Dust SCR: Schwenk Zement KG: Mergelstetten (Germany)
- Low Dust SCR: SPZ Gebr. Wiesböck GmbH: Rohrdorf (Germany)
- LaFarge: Joppa, Illinois (USA)

3.3.3 Activated carbon filter

Pollutants such as SO₂, organic compounds, metals (including volatile ones as mercury and thallium), NH₃, NH₄ compounds, HCl, HF and residual dust (after an ESP or fabric filter) may be removed from the exhaust gases by adsorption on activated carbon. The activated carbon filter is constructed as a packed-bed with modular partition walls. The modular design allows the filter sizes to be adapted for different gas throughputs and kiln capacity. (BREF CLM, 2013)

In principle, the adsorber consists of several vertical filter beds packed with lignite coke. Each filter bed is subdivided into a thin bed (0.3 m) and a thick one (1.2 m). The waste gas from the bag filter is pressed through the lignite coke adsorber by the fan. The bed height is about 20 m. In the first, thin bed, the waste gas is pre-cleaned while in the second, thick bed, the pollutants are further removed from the waste gas. The saturated lignite coke is recycled externally and is replaced by fresh or recycled coke. This exchange takes place semi-continuously in small steps (every 3 hours). Fresh coke is only charged to the thick beds through distribution troughs, moves down the filter bed (about 0.3 m/d). In the thin beds, the coke moves down to about 1.2 m/d. Therefore, it is called a moving bed adsorber. At the bottom of the thick filter beds, the lignite coke is withdrawn, and, by means of elevator conveyors, recycled back to the thin beds. Consequently, a counter current operation mode is

achieved. In 2007, the former electrostatic precipitator was replaced by a well-designed bag filter to achieve low dust contents prior to the adsorber.

Achieved environmental benefits

The most important characteristic of the activated carbon filter is the effective simultaneous removal of a broad spectrum of pollutants. Thereby, the removal efficiency is very high. Only some very volatile short chain hydrocarbons (C1- C4 molecules) are not efficiently captured and benzene is not totally removed. However, all other organic pollutants, including persistent organic pollutants (POPs) and also volatile heavy metals, especially mercury and thallium, are adsorbed with an efficiency of more than 90 per cent. Additionally, sulfur dioxide is reduced by more than 90 per cent. (Schoenberger, 2009)

Cross-media effects

Waste, such as used activated carbon with mercury and other pollutants such as PCDD/F have to be disposed of safely.

Increased electricity consumption due to pressure drop of the adsorber is the most important cross-media effect.

Applicability

The only activated carbon filter existing in the cement industry is installed at a cement works in Siggenthal, Switzerland. The Siggenthal kiln is a four stage cyclone preheater kiln with a capacity of 2000 tonne clinker/day. Measurements show high removal efficiencies for SO₂, metals and PCDD/F. During a 100 days trial, the SO₂ concentrations at the filter inlet varied between 50 and 600 mg/Nm³, whereas the outlet concentrations were always significantly below 50 mg/Nm³. Dust concentrations dropped from 30 mg/Nm³ to significantly below 10 mg/Nm³. (BREF CLM, 2013) An activated carbon filter can be fitted to all dry kiln systems. Monitoring and control of temperature and CO are especially important for such processes, to prevent fires in the coke filter (BREF CLM, 2013).

Economics

The system at Siggenthal also includes an SNCR process and in 1999, the city of Zürich financed about 30 per cent of the total investment cost of approximately EUR 15 million. The investment in this abatement system was made to enable the cement works to use digested sewage sludge as fuel. Operating costs may increase. (BREF CLM, 2013)

Reference plants

The only reference plant in the cement sector is the activated carbon filter (lignite coke moving bed adsorber) at the cement works of Holcim in CH-Siggenthal. However, lignite coke moving bed adsorbers have also been applied in other sectors, especially in the waste incineration sector.

4 Emerging Techniques

4.1 Mercury roaster

In the raw mill system, dust captured in the main baghouse acts as a natural adsorbent for mercury. This mercury enriched dust that is captured in the main baghouse is taken to the new mercury roaster process for cleaning before the dust is returned back to the system.

In this patented mercury removal process, the baghouse dust is fed to a roasting system which uses a heat source (for example kiln bypass gas, cooler vent gas, or hot gas generator) to heat the dust above the boiling point of mercury compounds. While the mercury is still in the gas phase, the gas enters a hot electrostatic precipitator which removes most of the cleaned dust. The dust is taken back to the blending silo to be part of the kiln feed. After the electrostatic precipitator, the gas stream is cooled below the mercury boiling point so that the mercury can condense on the dust particles that were not captured in the electrostatic precipitator. (flsmidth, 2015)

Pilot testing in a laboratory setting has achieved over 95 per cent mercury removal from the baghouse dust, and up to 75 per cent mercury emission reduction based on mercury cycle simulations. The mercury reduction rate is dependent on the mercury capture rate in the baghouse. (Paone, 2011)

4.2 Sorbent Polymer Catalyst (SPC) Technology

4.3 A TEC eXmercury Technology

5 Best available techniques and best environmental practices

Mercury emissions can be reduced by primary measures such as controlling the amount of mercury in the inputs to the kiln and secondary measures such as dust shuttling and sorbent injection. Mercury can also be controlled as a co-benefit of applying multi pollutant control measures such as wet scrubbers, selective catalytic reduction and activated carbon filters.

The performance level associated with best available techniques and best environmental practices in new and existing installations for control of mercury emissions to air is below 0.03 mg Hg/Nm³ as a daily average, or average over the sampling period, at reference conditions 273 K, 101,3 kPa, 10 per cent oxygen and dry gas.

Reported mercury emissions shows that the majority of cement plants worldwide have mercury emissions below 0.03 mg/Nm³. In the report Mercury in the Cement Industry (Renzoni et al., 2010) it was found that many values are under 0.001 mg mercury/Nm³ (under the detection limit) and very few values are higher than 0.05 mg mercury/Nm³.

5.1 Primary measures

Careful selection and control of raw materials and fuels entering the kiln is an effective way to reduce and limit mercury emissions. To reduce mercury input to the kiln the following measures can be taken:

- Use limit requirements on mercury content in raw materials and fuels.
- Use of a Quality Assurance System for input materials, especially for waste derived raw materials and fuels, for control of mercury contents in input materials.
- Use of input materials with low mercury content when possible, and avoid using waste with high mercury content.
- Selective mining if mercury concentrations vary in the quarry, when possible.
- Choose location for new facilities taking mercury content in the limestone quarry into account.

5.2 Secondary measures

There are a number of secondary measures that should be considered, as appropriate.

The emissions of mercury can be reduced by dust shuttling and collecting the dust instead of returning it to the raw feed. A way to further improve the effectiveness of dust shuttling is to lower the off-gas temperature after the conditioning tower to below 140°C to improve the precipitation of mercury and its compounds during dust filtration. The collected dust can be used in the cement finish mill or used for the production of other products. If this is not possible it has to be treated as waste and disposed of safely.

Dust shuttling combined with sorbent injection achieves higher mercury removal efficiency than dust shuttling alone. The sorbents are usually injected during raw mill off-operation aiming at cutting peak emission in this operation mode. Dust shuttling with sorbent injection can achieve very low mercury emission levels, the mercury emissions can be reduced by (70 – 90 per cent). The emission level depends on which target concentration the system is designed to achieve.

When using sorbent injection with a polishing bagfilter the sorbent is injected into the flue gas after the main dust control and using a second dust filter or “polishing” bag house to capture the spent sorbent. Depending on the required overall mercury emissions removal requirement the sorbent can be injected continuously, or for cutting peak emissions, which typically occur during raw mill off operation. The use of activated carbon injection with a “polishing” baghouse can achieve control efficiencies of 90 per cent mercury removal. Using these technologies, it has to be considered that the valorization of the shuttled dust in cement production may be limited and additional waste may be produced.

Additives which further oxidize the mercury such as bromine also can increase the mercury removal efficiency of sorbent injection.

5.3 Multi-pollutant control measures

Air pollution control devices installed for removing sulfur oxides and nitrogen oxides can also achieve co-benefits of mercury capture.

The wet scrubber is an established technique for flue gas desulfurization in the cement manufacturing process. Gaseous compounds of oxidized mercury are water-soluble and can absorb in the aqueous slurry of a wet scrubber system, and therefore, a major fraction of gas-phase oxidized mercury vapors may be efficiently removed. However, gaseous elemental mercury is insoluble in water and, therefore, does not absorb in such slurries unless additives to oxidize the mercury are used.

The selective catalytic reduction (SCR) technique reduces NO and NO₂ catalytically in exhaust gases to N₂ and, as a side effect, elemental mercury is oxidized to a certain extent. This oxidized mercury can be better removed from the gas stream in a subsequent dust filter or wet scrubber. This side effect can be used with the High Dust SCR technique, but not with Low Dust (Tail End) SCR.

Pollutants such as SO₂, organic compounds, metals (including volatile ones as mercury and thallium), NH₃, NH₄ compounds, HCl, HF and residual dust (after an ESP or fabric filter) may be removed from the exhaust gases by adsorption on activated carbon. The activated carbon filter is constructed as a packed-bed with modular partition walls. The modular design allows the filter sizes to be adapted for different gas throughputs and kiln capacity.

Using these techniques, cross media effects should be considered like shifting mercury streams to products such as gypsum from a wet scrubber, or producing additional wastes such as spent activated carbon which requires disposal

6 Monitoring

6.1 Introduction

General and cross cutting aspects of testing, monitoring and reporting are discussed in the introductory chapter of this document. Specific aspects inherent to cement production processes will be discussed in this chapter.

The objective of an emissions reporting scheme has an important impact on the type of monitoring chosen for a certain installation. Therefore, testing and monitoring comprise the material balance method (based on input sampling and analyses) and/or emission measurements (output) at the stack.

Emission limits for mercury in the cement process may be set as an average for a certain time period (e.g. 8 hours, 12 hours, 24 hours, 30 days) or may be specified for shorter period of time (e.g. 30 minutes) to prevent high peak levels. Emission limits may also be set in terms of the amount of mercury per amount of clinker produced (e.g. mg/t of clinker produced), like in the U.S., and in terms of concentration ($X \mu\text{g}/\text{Nm}^3$ at Y per cent of O_2 , dry basis) in the stack like in Europe. In some cases there are also limits on the amount of mercury in raw materials and fuels, mainly where alternatives are used. Testing and monitoring of mercury air emissions in the cement process need to take into consideration all the conditions set for the specific case being tested or monitored at a facility.

6.2 Sampling points for mercury in the cement process

According to the mercury input and output of the cement clinker production process discussed previously in this document, main sampling points for mercury in the cement process would be:

- for the material balance approach - the untreated raw materials and fuels, dust collected and removed from the system;
- for emission measurement - emission from stacks.

Emission measurements are important for comparison with emission limit values, if they have been set. Figure 1 of the first chapter illustrates a scheme of the main inputs and outputs of cement plants system, which are potential points for mercury monitoring.

6.3 Chemical forms of mercury in the cement process

Regarding the material balance method, the chemical binding of mercury in the solid materials is of low importance, as the risk of losing a part of the mercury during sampling and analysis is low. However, care has to be taken during storage and treatment of samples containing mercury, as some of it may get lost due to adsorption to containments or heating of the sample during treatment (e.g., grinding).

Regarding stack measurements, mercury may be in the form of elemental mercury or it can be in the oxidized form ((Hg(I) or Hg(II)), in vapor form. It may be also in particle-bound adsorbed form. Sampling and analysis must comprise total mercury. As analysis and detection are for elemental mercury, oxidized Hg must be converted to elemental mercury. Mercury oxidized compounds produced in the cement kiln are assumed to be e.g. HgCl_2 , HgO , HgBr_2 , HgI_2 , HgS and HgSO_4 . While

discrete sampling methods (spot samples) can handle both vapor and solid phases, continuous emission systems measure only the vapor phase since a particulate filter is used to protect the instrument. It can be accurate enough to measure gaseous mercury if efficient dust abatement is applied since the particle-bound mercury is very low at low dust concentrations.

6.4 Mercury sampling and measuring methods for cement process

Methods for sampling and measuring mercury in the cement process includes, for material balance, solid sampling and analyses of untreated raw materials and fuels, removed filter dust; and for emission measurements, spot sampling, semi-continuous method and continuous method at the stack, process control, and gas temperature in dust filter.

6.4.1 Material balance (Indirect Method)

The major pathways by which mercury leaves the cement kiln system is stack emissions and cement kiln dust, if it is removed from the kiln system.

System mercury mass balance may offer a better estimate of emissions than spot stack measurements. Variability of mercury levels in fuels and in input materials and representativeness of samples will influence the results of a spot sample.

In the material balance method, the sampling of raw material, fuels, and collected dust must lead to a representative sample. If wastes are co-incinerated, the variability of the composition could be greater and additional care must be taken in order to get a representative sample.

The American Society for Testing and Materials (ASTM) and European standards for sampling, and for initial preparation of solid sample for analysis, which were developed for coal sampling (Standards ASTM D2234¹ and D2013², and standard EN 932-1³), may be used in the sampling of inputs to the cement process.

Sampling should be performed periodically and may comprise a composite sample at the end of a certain period. For example, samples of raw material, fuel and dust collected may be taken daily or weekly, depending of the mercury content variation. If weekly samples are taken of raw material components and fuels, the monthly composite samples will be made from the weekly samples. Each monthly composite sample should be analyzed to determine mercury concentrations representative for the specific month.

The analytical methods used to determine mercury concentration may be EPA or ASTM methods such as EPA 1631⁴ or 7471b⁵. Chemical analysis is performed by cold vapor atomic absorption spectroscopy (CVAAS) or by cold vapor atomic fluorescence spectroscopy (CVAFS) or by inductively coupled plasma mass spectrometry (ICP-MS).

¹ ASTM Method D2234: Standard Practice for Collection of a Gross Sample of Coal

² ASTM Method D2013: Standard Method of Preparing Coal Samples for Analysis

³ European Standard EN 932-1: Tests for general properties of aggregates. Methods for sampling

⁴ US.EPA Method 1631: Mercury in Water by Oxidation, Purge and Trap, and Cold Vapor Atomic Fluorescence Spectrometry. Revision E, August 2012.

⁵ US.EPA Method 7471b: Mercury in solid or semisolid waste (manual cold-vapor technique). Revision 2. February 2007

The monthly input rate (input mass of mercury/month) is be the product of the mercury concentration of the monthly samples and the respective mass of raw material components feed and fuels introduced in the process. The consecutive 12-month mercury input rate (input mass mercury/year) is the sum of the twelve individual monthly records.

Advantages⁶: low annual cost relative to continuous and semi-continuous methods (assuming monthly sampling and 1 week composite sample pre month); medium accuracy representativeness for long term emission averages; medium precision; results are given mainly in total mercury;

Disadvantages: low accuracy at low emission levels; method may not be usable to demonstrate compliance with emissions limits depending on how emission limits are set.

6.4.2 Manual methods for mercury spot measurements (Impinger Methods)

Manual methods of stack sampling and analysis in the cement process play an important role in order to check compliance in the developing world, and they are frequently used for that purpose. In a few developed countries (Germany, U.S.) regulations are changing requirements from spot stack sampling to continuous sampling and analysis (CEMS or Sorbent Trap System) in order to provide for a better characterization of emissions. Measurement of mercury emission by manual methods can be part of an annual campaign for measuring emissions of other pollutants in the cement process.

Standards for spot measurement of mercury are mainly from Europe and the U.S. Japan also has its own standards. These may differentiate in terms of the form of mercury measured. Usual test methods for sampling and measuring mercury in stack emissions in Europe (EN methods) and in the U.S. (US EPA and ASTM methods), which can be used for cement plants are presented and briefly described in the main text of the introductory chapter.

For kilns with in-line raw mills, a key issue associated with any type of stack sampling is that mercury emissions typically vary significantly depending on the mode of raw mill operation. Testing during both raw mill on and off operating modes is necessary to quantify long term emissions.

Advantages: lowest annual cost relative to mass balance, continuous and semi-continuous methods; usually mercury is determined as part of a big measuring campaign for several pollutants, reducing the costs; spot measurement have been used all over the world; accuracy and precision at low levels of emission is medium to high; mercury speciation is possible.

Disadvantages: the results are only for short time, then it does not give a good picture of emissions with time; low accuracy for long term average representativeness; method may not be usable to demonstrate compliance with emissions limits depending on how emission limits are set.

6.4.3 Semi-continuous methods

The semi-continuous method uses sorbent material to trap Hg emission for further analysis by CVAFS. It can give a good characterization of emissions from a cement process and it may not be as expensive as CEMS, and are easier to operate and to maintain than CEMS. The reference methods are described in the Chapeau text.

⁶ Advantages and disadvantages for all methods are mainly based on Mazzi et al. (2006), for coal-fired power plants

In the U.S., sorbent trap based monitoring system are approved for mercury emissions monitoring in cement plants. Sorbent trap systems are not approved as a mercury emission monitoring system in the EU, due to the definition of the emission limit as daily average and partially at national level limits with even a shorter time. As in the USA the emission limit value is defined as (rolling) 30-day average the measurement with such a system is acceptable and widely used.

Advantages: medium annual cost compared to other methods listed; high accuracy for low mercury levels; medium to high representativeness of long term average emission; high precision.

Disadvantages: possible plugging of sorbent traps due to eventual high emissions of mercury, e.g. when mill is off; method may not be usable to demonstrate compliance with emissions limits depending on how emission limits are set; method does not provide continuous mercury data that can be used to operate mercury controls in the most efficient manner.

6.4.4 Continuous emission monitoring systems for mercury (mercury CEMS)

Continuous emission monitoring is an important tool to gain better knowledge about time- and operation-related variations of mercury emissions from stationary sources and to control the operation of mercury abatement devices. In Europe mercury CEMS are required in some countries like Austria and Germany for cement plants using alternative fuels.

In Germany cement kilns using alternative fuels must be equipped with mercury CEMS since the year 2000. The first generation of mercury CEMS was developed in the 1990s and underwent their suitability tests between 1994 and 2001. The experiences have shown that, despite the successful completion of the suitability testing, difficulties arose in practice with regard to the stable long-term operation of CEMS. Instruments were modified and improved over time, as part of the experience gained with their use.

In 2013 the U.S. approved a final rule setting national emission standards for hazardous air pollutant for the Portland cement manufacturing industry, which includes mercury specific limits. According to this rule, cement plants subject to limitations on mercury emissions will be required to comply with the mercury standards by operating a mercury CEMS or a sorbent trap based monitoring system.

Advantages: medium to high accuracy at low levels; high representativeness of long term averages; medium to high precision; provides continuous data that can be used to operate mercury controls in the most efficient manner.

Disadvantages: higher annual cost compared to other methods; periodic quality assurance procedures, calibration and maintenance need experienced personnel; requires calibration for both raw mill on and raw mill off operation because mercury levels typically go beyond the calibrated mill on span during mill off operation.

7 Appendix

7.1 Behaviour of mercury in clinker production plants

As temperature is the most important parameter for the behaviour of mercury and its compounds in the clinker production system, the different mercury species and the reaction conditions will be explained following the temperature profile (see Figure 7.1) starting at the hot end with the main burner of the rotary kiln and ending up with the dust filter and stack emissions.

Figure 7.1 also contains the temperature profile and provides a non-exhaustive overview of the possible reaction partners and the respective reaction products (ecra, 2010). It also points out that, in principle, there are three classes of mercury species: elemental mercury (Hg^0), mercurous (Hg^+) and mercuric (Hg^{2+}) forms.

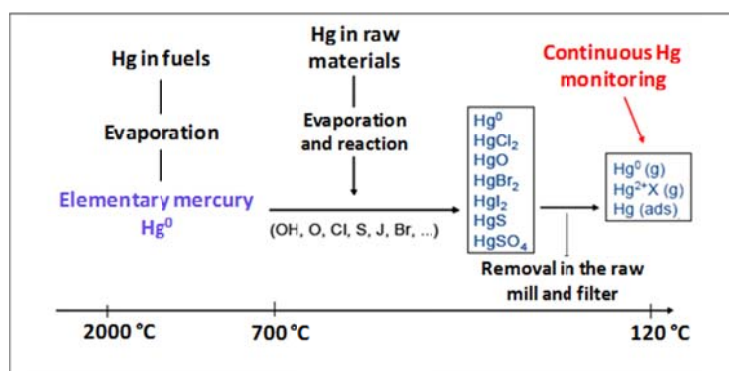

Figure 7.1: Scheme illustrating the possible conversion reactions of mercury in the clinker production process, (Renzonei et al., 2010; Oerter/Zunzer, 2011, ecra, 2013)

Three possible mercury input points (main burner, secondary firing/precalciner, raw meal) are important and will be discussed accordingly.

Main burner and rotary kiln

Thermodynamic equilibrium calculations indicate that above 700-800 °C, only elemental mercury is present in the gas phase (Martel, 2000; Schreiber et al., 2005; Krabbe, 2010). This is important for the main burner and the rotary kiln with gas temperatures up to 2,000 °C (see Figure 3). Thus, all mercury compounds entering the system via the main burner will be transformed into elemental mercury and will leave the kiln to enter the preheater. As already indicated in the previous section, practically no mercury is incorporated into the clinker.

Preheater

In the preheater, there are complex reaction conditions and a temperature profile of the gas phase of about 900-1,000 °C in the kiln inlet and 270-450 °C after the preheater. In case of the existence of a chlorine bypass in a plant, a part of the elemental mercury may be extracted and will be partly adsorbed to the filter dust and partly emitted to air. The elemental mercury from the kiln may be partly transformed to other species in the preheater.

The mercury input via the main burner is described above. The next input point is the secondary firing which could be the feeding of fuels (conventional or waste-derived fuels) to the kiln inlet or to a precalciner (see Figure 3). At temperatures above 700-800 °C, mercury, present in the fuel will be

converted to elemental mercury which, as described above, can be transformed to other mercury species in the preheater.

In clinker production plants, usually, the main mercury species are elemental mercury, mercury dichloride (HgCl_2) and mercury oxide (HgO); other mercury species are of less importance (ecra, 2013). All these three species have a high volatility. Mercury oxide decomposes at temperatures above 400°C .

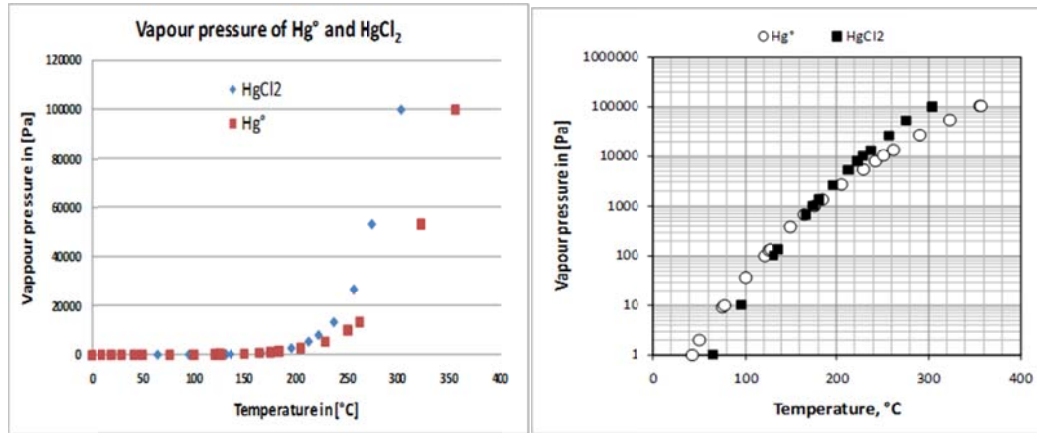

Figure 7.2: Dependence of the vapour pressure of Hg° and HgCl_2 on the temperature (left chart with linear scale and right chart with logarithmic scale) [Holleman-Wiberg, 1985; CRC Handbook, 1976; CRC Handbook, 1995; CRC Handbook, 2012]

The vapour pressure of elemental mercury and mercury chloride exponentially increases with temperature. This is illustrated in Figure 7.2 which shows the concerned curves with linear and logarithmic scale.

The numbers illustrate the high volatility of these mercury species. Consequently, they are volatilised in the preheater and leave it in the gas phase. These physico-chemical properties are confirmed by volatilisation tests of the raw meal which represents the third input. These tests indicate that the raw meal contains different mercury species which are volatilised between 180 and 500°C . The left chart in Figure 7.3 shows the mercury volatilisation curves of four different raw meals.

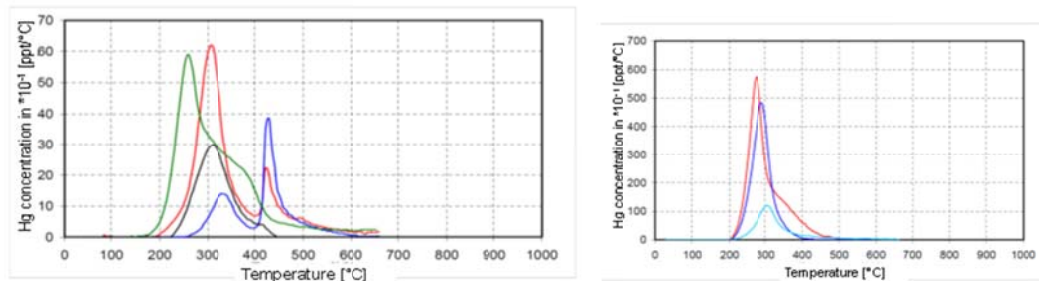

Figure 7.3: Hg volatilisation curves of 4 raw meals (left chart) and of 3 filter dusts (right chart) (AiF, 2008)

In comparison, the volatilisation curves for filter dusts are more narrow (180-400°C) indicating the presence of elemental mercury, mercury chloride and mercury oxide being adsorbed to the surface of the dust particles (right chart of Figure 7.3).

The aforementioned temperature range for the volatilisation of mercury species means that most of the mercury present in the raw meal is already volatilised in the first two upper cyclones of the preheater (AiF, 2008; Paone, 2008; Renzoni et al., 2010). Due to kinetics, the volatilisation may not be 100 per cent in the preheater but close to it and will be fully completed in the kiln.

It has already been indicated that mercury enriches between the preheater and the dust filter due to the formation of the aforementioned external cycle. Due to the decrease in the gas temperature and the adsorption, the mercury is removed to a certain extent (mainly depending on the gas temperature) with the filter dust which is recycled to the raw meal to be fed to the preheater where the mercury is volatilised again. Thus, an external mercury cycle is formed as illustrated in Figure 7.4 where filter dust recycling as well as its removal is considered.

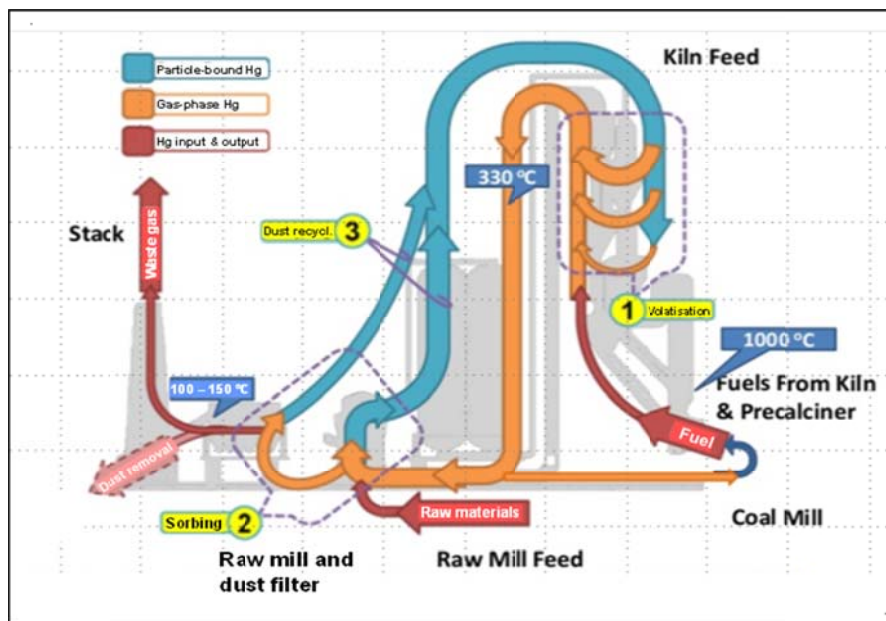

Figure 7.4: The external mercury cycle in a clinker production plant considering filter dust recycling and removal, based on (Sikkema et al., 2011)

The gas leaving the preheater has usually a clinker-specific dust content of 5 – 10 per cent, i.e. 50 – 100 g dust/kg clinker. Modern plants have more efficient upper cyclones. In these cases, the clinker-specific dust content is less than 5 per cent. However, directly after the preheater, most of the mercury species are still almost completely in the gas phase and not particle-bound. The heat of the waste gas is further recovered by heat exchange by passing it through the raw mill in order to dry the raw meal. In almost all modern systems with a roller mill, there is no conditioning of the gas before the raw mill and water spray is used in the raw mill to control the outlet temperature. In ball mill systems, water spray is sometimes used to control the outlet temperature in the mill, but more often the amount of hot gas taken to the raw mill is adjusted to control the outlet temperature and the balance of the gas is bypassed around the mill, often going through a conditioning tower before the filter (or being combined with the outlet mill gas before going to a filter). Water injection in a conditioning tower is always used in direct (raw mill off-operation).

The cooling in the raw mill or the conditioning tower leads to the first major shift of the mercury species from the gas phase to the dust particles. A small amount of dust also results from the conditioning tower.

In the raw mill, the heat exchange of the gas takes place and thus, the gas is further cooled down. For the temperature range 0-400 °C, it has been shown that the vapour pressure increases exponentially. This is also true for the temperature range in which the dust filters are operated (about 90-190 °C) (Figure 7.5).

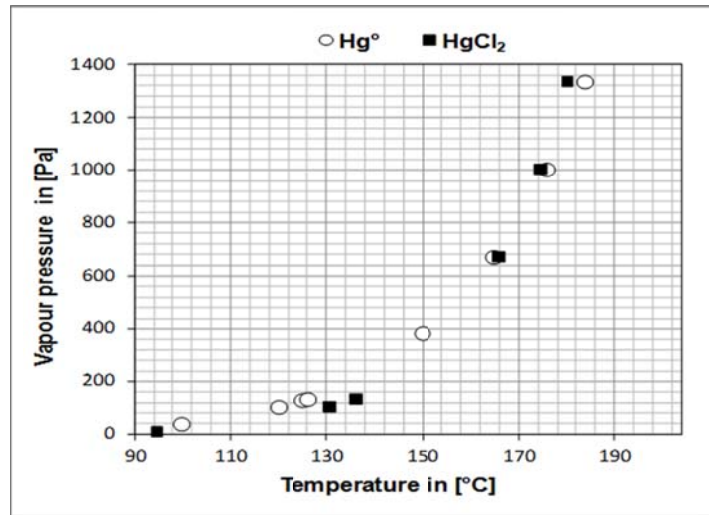

Figure 7.5: Dependence of the vapour pressure of Hg° and HgCl₂ on the temperature between 90 and 190 °C (Schoenberger, not published)

Looking at the curve, it appears to be logic that the minimisation of the waste gas temperature will result in a higher percentage of the particle-bound mercury which can be removed in dust filter. At optimised removal conditions, the dust particles will be removed to a very high extent. Thus, at waste gas temperatures below 130 °C, the mercury removal efficiency is more than 90 per cent (Kirchartz, 1994, p 79; Oerter, 2007; Hoenig, 2013; ecra, 2013).

In the compound operating mode (raw mill on), the exhaust gas passes the raw mill in order to dry the raw materials. In the majority of cases, there is usually a bypass of some of the preheater gases around the raw mill and these gases may not be cooled to the same extend before they are mixed with the raw mill exhaust before the filter.

From the silo, with the raw meal, the mercury is returned to the preheater where it volatilizes again and is removed again. Thus, the cycle is formed. Consequently, the silo acts as a big buffer and reservoir and contains the major part of the overall mercury present in the whole system at any given time (see Figure 7.4).

In case of the direct operating mode, the gas from the preheater fully passes the conditioning tower but not the raw mill but is directly directed to the dust filter; then, the gas is not cooled to the same extend compared with the compound operating mode. Therefore, on the one hand, the preheater dust (with its mercury content) is not diluted with the raw meal and on the other hand, the gas (the waste gas) temperature is higher as there is no heat exchange in the raw mill.

The relationships concerning the outer cycle, the enrichment of mercury, the influence of the waste gas temperature, and the operating modes were published and presented in a comprehensive way for the first time in 2001 (Schäfer/Hoenig, 2001). The figures of this publication have been republished a number of times (VDZ Activity Report, 2002; Oerter, 2007; Renzoni et al., 2010; Oerter/Zunzer, 2011; Hoenig, 2013; ecra, 2013). Figure 7.6 shows one of these graphs for the operation with recycling of the removed filter dust, i.e. for one week the mercury emission curve (values were determined continuously), the related waste gas temperature and the time periods of the compound and direct operation modes.

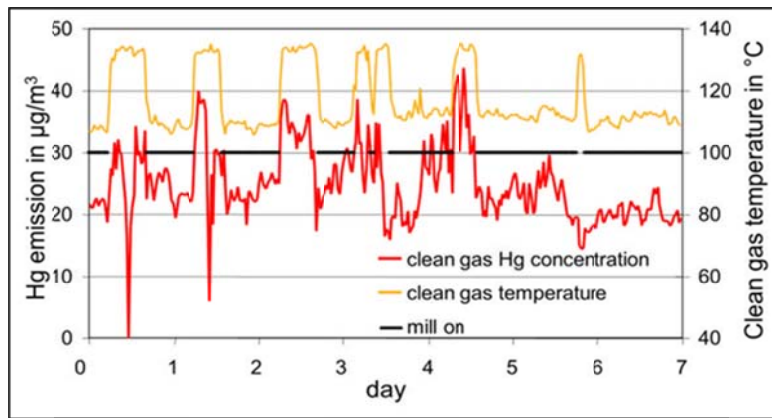

Figure 7.6: Mercury emissions from a dry rotary kiln for clinker production without filter dust recycling for one week along with indication of the waste gas temperature after the electrostatic precipitator (clean gas temperature) and the time periods with raw mill in operation (mill on), based on (Schäfer/Hoenig, 2001, also quoted in (VDZ Activity Report, 2002; Oerter, 2007; Renzoni et al., 2010; Oerter/Zunzer, 2011; Hoenig, 2013; ecra, 2013)

It is clearly demonstrated that the waste gas temperature and emissions are higher at direct operating mode. This is also due to the enrichment of mercury in the outer cycle during the compound operating mode. The percentage of direct operating mode was about 26 per cent. A shorter share of direct operating mode is often associated with higher enrichment factors. The example from 2001 clearly shows that mercury emissions are higher during the direct operating mode but the difference is less than a factor of two whereas much higher factors are reported from other plants: up to factor 400 (Linero, 2011).

The reasons for the different factors are:

- The dust content in the gas leaving the preheater; new or retrofitted preheater cyclones lead to lower dust contents and thus, after precipitation at lower temperatures, the mercury concentration of the dust is higher.
- The ratio of compound to direct operating mode is between 50:50 and 90:10. At higher ratios, the mercury can enrich more in the outer cycle and thus, the factor for the mercury emissions between compound and direct operating mode increases.
- The waste gas temperature; the lower the waste gas temperature, the lower the vapour pressure and the higher the precipitation of the mercury species on the dust particles.
- The removal efficiency of the dust filter; in former times, the emitted dust concentrations were 50-100 mg/Nm³. Since the application of well-designed bag filters,

dust concentrations of less than 10, even less than 1 mg/Nm³ are achieved. In combination with low waste gas temperatures, this also contributes to lower mercury emissions.

Another important factor is the removal of filter dust by means of a valve and to which extent the filter dust is removed. Figure 7.7 shows the scheme of using a valve to remove the filter dust.

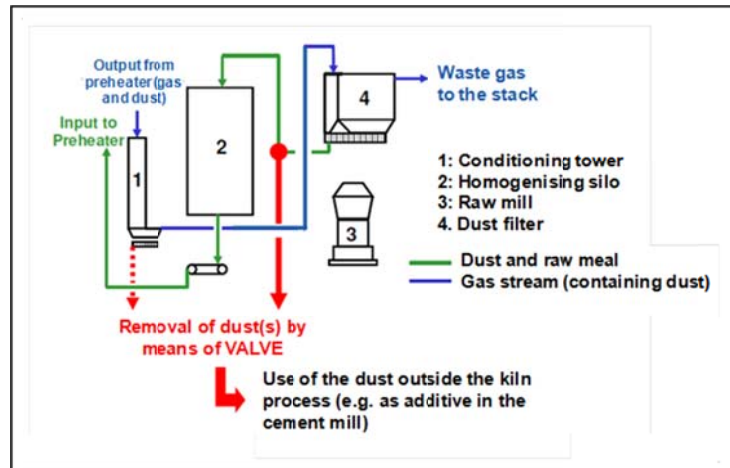

Figure 7.7: Scheme of the installation of a valve to remove filter dust (Waltisberg, 2013)

Then, the mercury emission is more constant as indicated in Figure 7.8. However, the indicated time period is relatively short (5 days) and the ratio of compound to direct operating mode is high (88:12) at that time (2001).

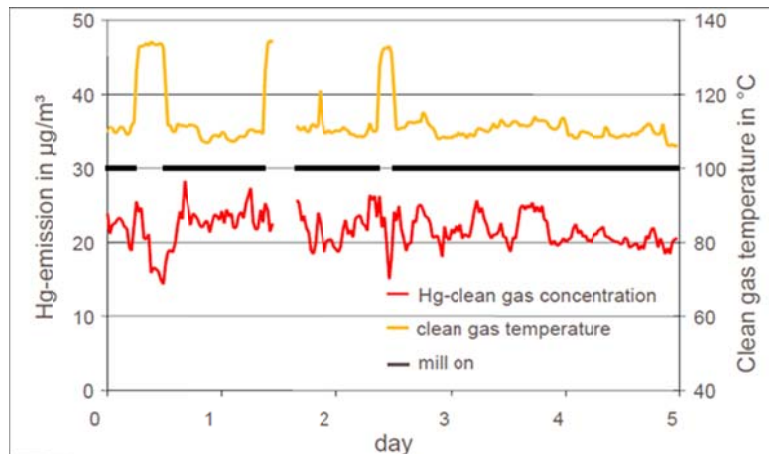

Figure 7.8: Mercury emissions from a dry rotary kiln for clinker production with filter dust recycling for five days with indication of the waste gas temperature after the electrostatic precipitator (clean gas temperature) and the time periods with raw mill in operation (mill on), based on (Schäfer/Hoenig, 2001, also quoted in (VDZ Activity Report, 2002; Oerter, 2007; Renzoni et al., 2010; Senior et al., 2010; Oerter/Zunzer, 2011; Hoenig, 2013; ecra, 2013)

The effect of dust removal is obvious.

Figure 7.9 shows the calculated impact of the percentage of direct operating mode without dust removal and with a percentage of dust removal of 100 per cent during direct operating mode on mercury emissions. The difference for the compound operating mode is very small whereas it is significant for the direct operating mode. If no dust is removed, the mercury emissions to air significantly increase, provided the removal efficiency of the dust filter is constant. Due to dust removal, the mercury emissions can be reduced by up to 35-40 per cent depending on individual conditions. However, the chart of Figure 7.9 provides an example with certain assumptions. In other cases, the reduction can be less but also higher, e.g. 78 per cent as reported elsewhere (Renzoni et al., 2010, p X). Practical cases mainly show reduction rates between 10 and 35 per cent.

The mercury concentration of the filter dust also depends on the individual circumstances. If the mercury removal efficiency of the dust filter is more than 90 per cent, the waste gas temperature around 100 °C, the ratio of compound to direct operating mode about 90:10, and the mercury input level not on a low level, the mercury concentration in the filter dust of up to 40 mg/kg can be reached (Renzoni et al., 2010, p XI).

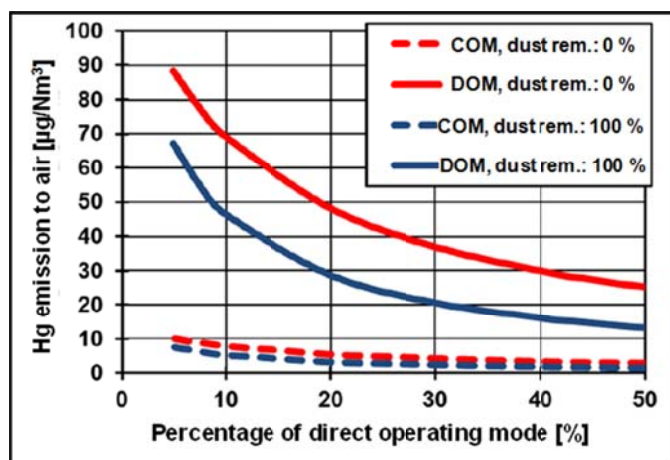

Figure 7.9: Impact of the percentage direct operating mode without dust removal and with a percentage of dust removal of 100 per cent during direct operating mode.

Legend: COM: compound operating mode; DOM: direct operating mode

7.2 Emitted mercury species

The transport and deposition of atmospheric mercury depend greatly on whether the mercury is elemental or oxidised (UNEP Hg Assessment, 2013, p 19). Elementary mercury stays in the atmosphere long enough for it to be transported around the world (the currently believed lifetime in the atmosphere is between 0.5 and 1.5 years), whereas oxidised and particulate mercury have much shorter lifetimes (hours to days) and are therefore subject to fast removal by wet or dry deposition (UNEP Hg, 2008, p 65). Consequently, the gaseous elemental mercury is a global pollutant whereas oxidised mercury compounds and those associated with particles are deposited regionally (UNEP Hg, 2008, P 65). As the mercury binding is furthermore relevant for capturing the mercury, it is of importance to know which species are emitted from cement plants.

In Figure 7.10 concerned data are compiled from different sources. There are plants where elemental mercury dominates and others where this is the case for oxidised mercury. The ratio of elemental to oxidized mercury emitted depends on the individual conditions, which means that no relationship can be established.

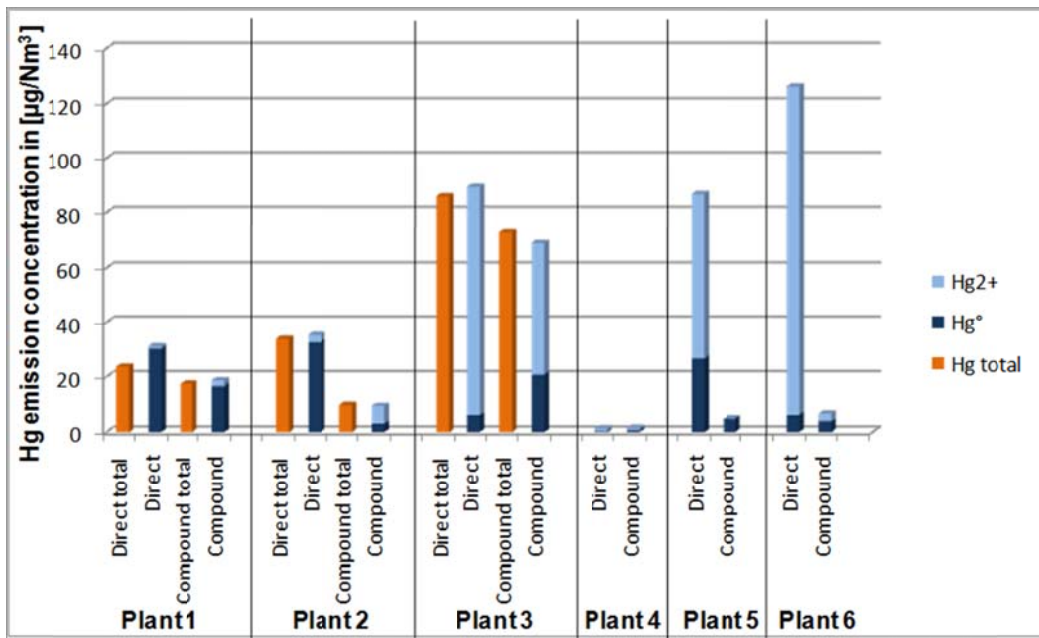

Figure 7.10: Emissions to air of elemental and oxidised mercury according to different sources

Indications for the sources of data:

Plant 1 and plant 2: (Oerter/Zunzer, 2011)

Plant 3: (VDZ Activity Report, 2002)

Plant 4: (Mlakar et al., 2010)

Plant 5 and plant 6: (Linero, 2011)

8 References

(AiF, 2008)

Angewandte industrielle Forschung (AiF), AiF-Forschungsvorhaben-Nr. 14547 N: Betriebstechnische Möglichkeiten zur Minderung von Hg-Emissionen an Drehrohranlagen der Zementindustrie (2008)

(BREF CLM, 2013)

Reference Document on Best Available Techniques in the Cement, Lime and Magnesium Oxide Manufacturing Industries, (2013), online:

http://eippcb.jrc.ec.europa.eu/reference/BREF/CLM_Published_def.pdf

(Barnett, 2013)

Barnett, K. (official of the US-EPA), Final Portland Cement Rule 2013, http://www.unep.org/chemicalsandwaste/Portals/9/RoundTableMercury_6_24-13-final.pdf

(CEMBUREAU, 1997). "BAT for the cement industry, November 1997 / Information for cement and lime BREF 2001

(CRC Handbook, 1976)

Weast R.C., CRC Handbook of Chemistry and Physics 1976-1977, CRC Press, Inc., 57rd edition (1976), D-185-D-191

(CRC Handbook, 1995)

Lide3, D.R., CRC Handbook of Chemistry and Physics 1995-1996, CRC Press, Inc., 76rd edition (1995), 6-77 and 6-110

(CRC Handbook, 2012)

Haynes, W.M.; Lide, D.R.; Bruno, T.J., CRC Handbook of Chemistry and Physics 2012-2013, CRC Press, Taylor&Francis Group Boca Raton/USA, 93rd edition (2012), 6-88-9-92

(ecra, 2013)

Hoenig, V.; Harrass, R.; Zunzer, U.; Guidance Document on BAT-BEP for Mercury in the Cement Industry, Technical report of the European Cement Research Academy (ecra) on behalf of WBCSD Cement Sustainability Initiative (2013)

(Erhard/Scheuer, 1993)

Erhard, H.S.; Scheuer, A., Brenntechnik und Wärmewirtschaft, Zement-Kalk-Gips 46 (1993) No. 12, 743-754

(Eriksen et al., 2007)

Eriksen, D.Ø.; Tokheim, L.-A.; Eriksen, T.A.; Meyer, J.; Qvenild, C., Assessment of mercury emissions at Norcem's cement kiln by use of 203Hg-tracer, Journal of Radioanalytical and Nuclear Chemistry 273 (2007) No. 3, 739-745

(flsmidth, 2015)

Mercury roaster system, <http://www.flsmidth.com/en-US/Industries/Categories/Products/Air+Pollution+Control/Mercury+Roaster/Mercury+Roaster>

(Hoenig, 2013)

Hoenig, V., Sources of mercury, behavior in cement process and abatement options, Presentation at the event "Cement Industry Sector Partnership on Mercury, Partnership Launch Meeting" of European Cement Research Academy on 19 June 2013, http://www.unep.org/hazardoussubstances/Portals/9/ECRA_WBCSD-CSI%20Mercury_20130618_upload.pdf

(Holleman-Wiberg, 1985)

Holleman, A.F.; Wiberg, E., Lehrbuch der Anorganischen Chemie, 91.-100. Verbesserte und stark erweiterte Auflage, Walter de Gruyter, Berlin/New York (1985), pp 1042-1049

(Kirchartz, 1994)

Kirchartz, B., Reaktion und Abscheidung von Spurenelementen beim Brennen des Zementklinkers, VDZ-Schriftenreihe der Zementindustrie, (1994)Heft 56, Verlag Bau + Technik, Düsseldorf

(Krabbe, 2010)

Krabbe, H.-J., Grundlagen zur Chemie des Quecksilbers am Beispiel von Rauchgasreinigungsanlagen, Manuscript of the presentation at the 'VDI Wissensforum – Messung und Minderung von Quecksilberemissionen' on 28 April 2010 in Düsseldorf/Germany (2010)

(Linero, 2011)

Linero, A.A., Synopsis of Mercury Controls at Florida Cement Plants, Manuscript for the presentation at 104th Annual Conference and Exhibition of the Air and Waste Management Association in Orlando, Florida/USA on 22 June 2011 (2011)

(Locher, 2000)

Locher, F.W., Zement - Grundlagen der Herstellung und Verwendung, Verlag Bau und Technik (2000)

(Mazzi, 2006)

Mazzi E., Glesmann, S., Bell, A (2006). Canada Wide Standards Mercury Measurements methodologies for coal-fired power plants. EPRI-EPA-DOE-AW&MA Power Plant Air Pollutant Control "MEGA" Symposium, August 28-31, 2006, Baltimore, Maryland, USA

<http://www.ires.ubc.ca/files/2010/05/MazziMegapaper152006final.pdf>.

(Mlakar et al., 2010)

Mlakar, L.T.; Horvat, M.; Vuk, T.; Stergaršek, A.; Kotnik, J.; Tratnik, J.; Fajon, V., Mercury species, mass flows and processes in a cement plant, Fuel 89 (2010) pp 1936-1945

(Martel, 2000)

Martel, C., Brennstoff- und lastspezifische Untersuchungen zum Verhalten von Schwermetallen in Kohlenstaubfeuerungen, VDI Fortschritts-Berichte, Reihe 15, Nr. 225 (2000)

Netherlands (1997)

"Dutch notes on BAT for the production of cement clinker / Information for cement and lime BREF 2001

(Oerter, 2007)

Oerter, M., Influence of raw materials on the emissions of mercury, presentation at the seminar of the European cement research academy (ecra) on 26 April 2007

(Oerter/Zunzer, 2011)

Oerter, M.; Zunzer, U., Messung und Minderung von Quecksilber in der Zementindustrie, Manuscript and presentation of/at the VDI Fachkonferenz „Messung und Minderung von Quecksilber-Emissionen“ on 13 April 2011

(Paone, 2008)

Paone, P.; Heavy metals in the cement industry: A look at volatile cycles and simple mitigation techniques, <http://www.asocem.org.pe/bivi/sa/dit/icem/01-04-2008.pdf> (accessed 14.11.2013)

(Paone, 2009)

Paone, P., Mercury reduction technologies for cement production, 7th Colloquia of managers and technicians of cement plants -Development, innovation and sustainability: the three cornerstones of cement industry” in Malaga/Spain in November 2009

(Paone, 2011)

Paone, P.; Mercury emissions controls for cement production,
http://www.marama.org/presentations/2011_ICACAdvancesCT/Paone_MARAMA_051811.pdf

(Renzoni et al., 2010)

Renzoni, R.; Ullrich, C.; Belboom, S.; Germain, A., Mercury in the Cement Industry, Report of the University of Liège independently commissioned by CEMBUREAU (2010), online: www.unep.org/hazardoussubstances/Portals/9/Mercury/A_Inventories/CEMENT%20Industry%20-%20Hg%20report%20CEMBUREAU%20April%202010.pdf

(SC BAT Cement, 2008)

Secretariat of the Stockholm Convention on Persistent Organic Pollutants, Guidelines on Best Available Techniques and provisional Guidance on Best Environmental Practices relevant to Article 5 and Annex C of the Stockholm Convention on Persistent Organic Pollutants, Section V.B. – Part II Source category (b): Cement kilns firing hazardous waste (2008)

(Schäfer/Hoenig, 2001)

Schäfer, S.; Hoenig, V.; Operational factors affecting the mercury emissions from rotary kilns in the cement industry, *Zement Kalk Gips* 54 (2001) No. 11, 591-601

(Schoenberger, 2009)

Schoenberger, H., Integrated pollution prevention and control in large industrial installations on the basis of best available techniques – The Sevilla Process, *Journal of Cleaner Production* 17 (2009) 1526–1529

(Schäfer/Hoenig, 2002)

Schäfer, S.; Hoenig, V., Effects of process technology on the behaviour of mercury in the clinker burning process: Technical Field 6: Sustainability and cement production; Presentation slides and documentation in: *Process Technology of Cement Manufacturing: VDZ Congress 23-27 September 2002 in Düsseldorf/Germany*, Verein Deutscher Zementwerke (VDZ) (Hrsg.), Verlag Bau+Technik (2003) p 484-488

(Schreiber et al., 2005)

Schreiber, R.J.; Kellet, C.D.; Joshi, N., Inherent Mercury Controls Within the Portland Cement Kiln System, *Research & Development Information*, Skokie, Illinois/USA, Portland Cement Association, Serial No. 2841 (2005)

(Sikkema et al., 2011)

Sikkema, J.K.; Alleman, J.E.; Ong, S.K.; Wheelock, T.D., Mercury regulation, fate, transport, transformation, and abatement within cement manufacturing facilities: Review, *Science of the Total Environment* 409 (2011) 4167 – 4178

(Sprung, 1988)

Sprung, S., Spurenelemente, *Zement-Kalk-Gips* 41 (1988) No. 5, 251-257

(Ullmann's, 1986)

Locher, F.W.; Kropp, J., Cement and Concrete, in Ullmann's Encyclopedia of Industrial Chemistry, 5th ed., Vol. A 5 (1986) 489-537

(UNEP Hg, 2008)

UNEP, Technical Background Report to the Global Atmospheric Mercury Assessment (2008),

(UNEP Hg Assessment, 2013)

UNEP, Global Mercury Assessment 2013: Sources, emissions, releases, and environmental transport (2013), <http://www.unep.org/PDF/PressReleases/GlobalMercuryAssessment2013.pdf>

(US Cement, 2007)

USEPA, Letter from F.L Steitman, Vice President, Environmental Affairs, Ash Grove Cement Company to Keith Barnett, SSPD/USEPA. October 1, 2007 accessed at www.regulations.gov, [EPA-HQ-OAR-202-0051-3371]

(US Cement, 2010 Cost)

USEPA, Summary of Environmental and Cost Impacts for Final Portland Cement NESHAP and NSPS, 6 August 2010 available online at http://www.epa.gov/ttn/atw/pcem/summary_impacts.pdf

(VDZ Activity Report, 2002)

Verein deutscher Zementwerke e.V. (VDZ), Activity Report 1999-2001 (2002)

(Waltisberg, 2013), Waltisberg, J., personal communications (2013)

(Waltisberg)

Waltisberg, J.; Schönberger, H (sd). Continuous and semi-continuous monitoring of mercury in waste gas from industrial installations. (Not published yet)

(Weisweiler/Keller, 1992)

Weisweiler, W.; Keller, A., Zur Problematik gasförmiger Quecksilber-Emissionen aus Zementwerken, Zement-Kalk-Gips (45 (1992) No. 10, 529-532

(Zheng, 2011)

Zheng Y., Mercury Removal from Cement Plants by Sorbent Injection upstream of a Pulse Jet Fabric Filter, PhD Thesis at the Technical University of Denmark (2011), <http://wwwx.dtu.dk/upload/kt-chec/phd%20thesis,%20yuanjing%20zheng,%20endelig%20version,%20klar%20til%20print.pdf> (accessed 23 January 2014)

(Zheng et al., 2012)

Zheng, Y.; Jensen, A.D.; Windelin, C.; Jensen, F., Review of technologies for mercury removal from flue gas from cement production processes, Progress in Energy and Combustion Science 38 (2012) 599-629